



FINAL REPORT

Grant Agreement number: **256673**

Project acronym: **D-CODE**

Project title: **DC/DC Converter-based Diagnostics for PEM systems**

Funding Scheme: **Collaborative Project (CP)**

Date of latest version of Annex I against which the assessment will be made: **15 December 2010**

Period covered: from **1st March 2011** to **31th May 2014**

Name, title and organisation of the scientific representative of the project's coordinator:

Cesare Pianese, Professor, University of Salerno

Tel: +39.089.96.4081

Fax: + 39.089.96.4037

E-mail: pianese@unisa.it

Project website address: <http://www.d-code-jti.eu>



Instrument: Collaborative Project (CP)	Thematic Priority FUEL CELL AND HYDROGEN JOINT UNDERTAKING
--	--

Contractual Delivery Date: July 2014	Actual Delivery Date: July 2014
--	---

Start date of project: March, 1 st 2011	Duration: 39 months
--	-----------------------------------

Organization name of lead contractor for this deliverable: INNO	Document version: Final
---	---------------------------------------

Dissemination level (Project co-funded by the European Commission within the Seventh Framework Programme)		
PU	Public	X
PP	Restricted to other programme participants (including the Commission)	
RE	Restricted to a group defined by the consortium (including the Commission)	
CO	Confidential, only for members of the consortium (including the Commission)	

Table of Content

LIST OF SYMBOLS AND ACRONYMS	4
PROJECT BENEFICIARIES	5
1. FINAL PUBLISHABLE SUMMARY REPORT	6
1.1. D-CODE Executive summary.....	6
1.2. Project Summary context and objectives.....	7
1.2.1. Introduction.....	7
1.2.2. Context.....	7
1.2.3. Project objectives.....	8
1.3. Main S&T results.....	11
1.3.1. Project general description.....	11
1.4. Expected impact.....	22
1.4.1. Expected outcomes and target achieved.....	22
1.4.2. Dissemination.....	23
1.4.3. Exploitation of results.....	26
1.5. The project public website.....	28
2. USE AND DISSEMINATION OF FOREGROUND	31
Section A.....	31
2.1.1. List of all scientific (peer reviewed) publications related to the foreground of the project.....	31
2.1.2. List of all dissemination activities.....	33
3. REPORT ON SOCIETAL IMPLICATIONS	36

List of Symbols and Acronyms

AIP	Annual Implementation Plan	HT	High temperature
MAIP	Multi Annual Implementation Plan	HV	High voltage
AAU	Aalborg University	IT	Information Technology
AC	Alternate current	LT	Low temperature
ANFIS	Adaptive Neuro-Fuzzy Inference System	LV	Low voltage
BoP	Balance of Plant (auxiliary devices)	Mi	Timing of the project, from M1 (start) to M39 (end)
DC	Direct current	OC	Open Circuit
DOW	Description of Work (annex I to GA)	PEM	Proton Exchange Membrane
ECM	Equivalent Circuit Model	SOFC	Solid Oxide Fuel Cells
EIS	Electrochemical Impedance Spectroscopy	SoH	State of Health
FC	Fuel Cell stack	TRL	Technology Readiness Level
FCS	Fuel Cell System	URL	Uniform Resource Locator
FIS	Fuzzy Inference Systems	μ CHP	Micro Combined Heat and Power
GA	Grant Agreement		

Project beneficiaries

Beneficiary Number	Beneficiary name	Beneficiary short name	Country	Organization type
1 Coord.	Università degli Studi di Salerno	UNISA	Italy	UNI
2	European Institute For Energy Research	EIFER	Germany	RES
3	Université de Franche-Comté	UFC	France	UNI
4	Dantherm Power A/S	DANTH	Denmark	SME
5	CIRTEM	CIRTEM	France	SME
6	Bitron S.p.A	BITRON	Italy	IND
7	Inno TSD SA	INNO	France	SME

1. Final publishable summary report

1.1. D-CODE Executive summary

Among the main technological challenges of PEMFC System (PEMFCS), long duration, reliability and optimal working operations of both stack and auxiliaries are issues of primary importance. Solving these problems will give a great opportunity for a decisive breakthrough towards mass diffusion of the current PEM technology. The need for advanced diagnostic tools is of prominent significance to improve the lifetime of PEMFCS. Diagnostic algorithms can detect malfunctioning of components and give alarms for faults that may hinder correct operations or induce system's failures. The D-CODE project has developed an innovative monitoring procedure to support the diagnosis of PEM fuel cell stack for fault identification. The stack electrochemical impedance spectrum (EIS) is proposed for on-line diagnosis during on-field operations. To synthesize in a statement: the project implements the idea that a single measure (i.e. EIS) provides holistic information on the stack. Indeed, EIS is the most reliable diagnostic tool for FC and the project D-CODE moves the EIS-based diagnostic from laboratory to on-field. Therefore, the main issue was to transpose the EIS from lab-scale to on-board as well as to develop innovative FC stack monitoring to change radically the concept of on-line diagnosis. In perspective, on-board EIS may support stack degradation level analysis as well as lifetime prediction and effective control to mitigate the consequences of degradation due to chemical, thermal and humidity effects as well as load cycles or faults.

To cover most of the prospective stationary use of PEMFCSs (μ CHP, backup and APU), two PEM technologies were considered, namely low temperature (LT) and high temperature (HT) for both high voltage (HV) and low voltage (LV) applications. Moreover, an additional device with a dedicated diagnostic function was developed to monitor the status of the stack when the FCS is switched-off. Towards the objective of implementing the EIS-based diagnostic functions on board of a FCS, the project addressed the development of new hardware and diagnosis algorithms that were embedded into the FCS. Moreover, a comprehensive experimental campaign was performed to identify the behaviour of the FC stacks under abnormal operating conditions to look into the influence of auxiliary devices (BoP) on stack impedance, as well as to validate the developed diagnostic algorithms. Another objective was building a diagnostic tool which may be implemented into any FCS with the minimum change of both hardware and software. Therefore, flexibility and modularity were also addressed during hardware and diagnosis algorithms design.

Two DC/DC converters for LV and HV uses were built and connected to an EIS-oriented controller board, which may be either implemented in any converter or connected via communication interface. The main feature of such a board is the control of voltage and current converter loops to inject the current stimuli to perform the EIS. This configuration guarantees the maximum flexibility to make the EIS-based diagnosis easy to install on any PEMFCS by substituting the conventional DC/DC converter or by adding the EIS control board. Three diagnostic algorithms were implemented making use of two approaches, namely model- and knowledge-based. The validation of these algorithms was successfully performed achieving the isolation of the following abnormal operations: air and fuel starvation, flooding, drying. A diagnostic tool was built and embedded into the controller of the FCS tested during the project. It was easily interfaced thanks to the use of conventional software functions and standard communication protocols. This guaranteed the development of a diagnostic tool that has industrial standards and marketable potentialities and is potentially implementable in any FCS.

Thanks to both the new DC/DC converter hardware and diagnostic algorithms, faults and potential failures associated to electrochemical processes, components faults (e.g. blower, power electronics, actuators) or having external origin (erroneous control, critical load) can be detected on-line while the system runs. Moreover, the main D-CODE project concept can be easily applied to other FC technologies (e.g. SOFC) thanks to the "universal" hardware and generic theoretical and experimental methodologies implemented.

1.2. Project Summary context and objectives

1.2.1. Introduction

The leading objective of the project D-CODE was the implementation of the electrochemical impedance spectroscopy (EIS) for on-line monitoring and diagnosis of PEM FC during on-field operations. The D-CODE project aimed at developing an innovative diagnostic procedure to detect PEM fuel cell faults and support stack degradation level analysis. To synthesize in a statement: the project implements the idea that a single measure (i.e. EIS) provides holistic information on the stack. Indeed, EIS is the most reliable diagnostic tool for FC and the project D-CODE moves the EIS-based diagnostic from laboratory to on-field. Therefore, the main issue was to transpose the EIS from lab-scale to on-board as well as to develop innovative FC stack monitoring to change radically the concept of on-line diagnosis. Moreover, an additional diagnosis function was developed to monitor the status of the stack when switched-off. The project plans were conceived in such a way to analyse and develop each component of the diagnosis tool and this was mostly achieved during the first part of the activity, then in the second period all elements of hardware and algorithms were tested and assembled for the final validation.

A diagnostic tool made of hardware and software parts and based on the electrochemical impedance spectroscopy concept was built; it gives direct and meaningful information about the FCS status during real operations. The project achieved its targets whose main results are i) the application of the EIS-based diagnosis for on-field application and ii) the development of affordable diagnostic equipment. It was demonstrated the possibility to move the EIS from controlled, clean and costly context (i.e. laboratory) towards unattended, contaminated and cheap environment (i.e. on-field). The D-CODE diagnostic concept relies on the combination of power electronics hardware and diagnostic algorithms, whose functions can be easily extended to other applications of PEM fuel cell systems and, in perspective, to all FC technologies as well. The D-CODE project's outcomes are expected to improve management and operational capabilities of PEM FCS as well as to increase maintenance time and reduce degradation rate. These achievements are crucial and will foster the deployment of PEM fuel cells for on field use.

As shown hereinafter, the objectives were achieved with satisfactory results. Such a positive outcome was obtained thanks to a good balance of complementary skills brought by the partners that cover all relevant areas: industry, innovation, research, and academia. This guaranteed the development of a diagnostic tool that has industrial standards and marketable potentialities and a Technology Readiness Level of 4 (i.e. TRL 4 – technology validated in lab)¹.

1.2.2. Context

In the last years PEM fuel cells have demonstrated great potentialities for automotive and stationary applications. Research and industry communities tackled significant technological problems with remarkable achievements that make the PEM fuel cells outstanding solutions for future energy and environment challenges. Materials and production technologies have guaranteed the attainment of notable performance at costs that are getting closer to those of the conventional energy conversion systems. Moreover long duration, reliability and optimal working operations of both stack and auxiliaries are issues of primary importance and further efforts are required for their improvement. The classical approach to face these problems relies mostly on basic research (e.g. new materials) with massive recourse to expensive and long experimental campaigns, often driven by trial and error analysis. A step forward in solving these problems is the exploitation of advanced methodologies available in the broad area of applied research. Among others, advanced control and diagnosis solutions – supported by ad hoc experiments and modelling approaches – would provide suitable solutions towards the achievement of more performing and durable FC. This paradigm would benefit also other FC technologies (e.g. SOFC).

¹ Mankins, J. C. (1995), Technology Readiness Levels: A White Paper, NASA, Office of Space Access and Technology, Advanced Concepts Office, available at <http://www.hq.nasa.gov/office/codeq/trl/trl.pdf> .

Following the trend seen in the high tech industry, a reduction in the actual empiricism together with more intelligent tools² installed on-board may lead to better performance and longer lifetime. The project D-CODE faced these problems from the point of view of monitoring and diagnosis, which are the first efforts which can impact on performance and lifetime of PEMFC system. Diagnostic algorithms can detect components malfunctions and give alarms for faults that may hinder correct operations or induce system's failures. The work has progressed its main activity to develop an advanced monitoring and diagnostic tool making use of electrochemical impedance spectroscopy (EIS). EIS can provide significant insights into the stack status and can support effective control to mitigate the consequences of degradation due to chemical, thermal and humidity effects as well as load cycles or faults.

The EIS is a steady-state technique able to observe phenomena occurring in electrochemical systems. On a FC, small-amplitude sinusoidal perturbations are superimposed over the nominal operating current at several discrete frequencies. Each injected perturbation induces a change into the output voltage that is out-of-phase with respect to the current perturbation signal. The electrochemical impedance is the frequency-dependent proportionality factor between the voltage response and the current signal; its real and imaginary components may be plotted to generate the Nyquist plot with characteristic semicircle shapes. Furthermore, the EIS is the response of the system to codified and reproducible inputs (stimuli) generated on purpose under dynamic operations. The electrochemical impedance provides the most meaningful information about the cell electrochemical processes providing unique information on the status of the FC.

It is worth noting that the impedance spectrum brings much information with only one measurement; this is in contrast with conventional techniques, which need more than one measurement to generate a single feature³. Indeed, the techniques available today rely on either simple heuristic approaches or burdensome mathematical models combined to many experimental measurements. Models and maps are used to generate reference (i.e. normal) system features to be compared to the actual ones, extracted from a real working system. To make useful diagnosis, redundant features must be computed and interpreted.

1.2.3. Project objectives

The objective of the project D-CODE was the development of a diagnostic tool, made of hardware and software parts and based on the electrochemical impedance spectroscopy concept, which gives direct and meaningful information about the FC status during real operations. At methodological level, the project aimed at reducing the empiricism found in most control and diagnostic algorithms and devices. Therefore, a more general objective was the exploitation of advanced techniques introducing in the field those innovations and approaches relying on advanced concepts and theories.

The main innovation of D-CODE is the exploitation of the Electrochemical Impedance Spectroscopy during real operations of fuel cell system (FCS). The on-board implementation of EIS is a breakthrough innovation for FC area because of its potentiality for the monitoring of the FC systems while running on-field. This was the main technological objective, which has been achieved making use of conventional hardware and manufacturing technologies at affordable industrial costs.

At the beginning of the project two main targets were set:

1. The first target dealt with the development of the power stage and the control strategy of DC/DC converter to measure the stack impedance spectrum. Towards this goal two devices for high and low voltage applications were built making use of power electronic methodologies. Furthermore, high flexibility has been achieved through the development of an EIS-oriented controller board, which may be potentially implemented on conventional converter as well. Also the integration of EIS functions through signal injection was achieved together with filtering and data collection for EIS analysis. The

² FCS controller refers herein to the broad application area of devices and algorithms dealing with control, monitoring and diagnosis.

³ According to Isermann (Fault-Diagnosis Applications, Springer, 2011), a feature is a characteristic property of a system whose deviation from normal value is a symptom of a possible fault.

data exchange with FCS controller was successfully tested and integrated within the main management functions.

2. The second target was the derivation of a set of indicators from the spectrum to quantitatively evaluate on-board either a drift or a difference between the actual status and nominal/expected performance of the stack/system. Two monitoring approaches, namely model- and knowledge-based were developed and tested. The diagnostic algorithms provide a quantitative framework that reduces the empiricism of the analysis performed today to derive the diagnosis of FC at both on-field and lab scale.

To achieve these goals several technological issues were addressed, among others:

- Derive FC degradation/diagnostic information while the system runs.
- Implement EIS functions to control the DC/DC converter.
- Embed the EIS-based diagnostic tool into the FCS control unit.

A relevant advantage gained by the project concerns with future on-field use that would benefit from the functional scheme where single components are linked together (see figures 1.1, 1.3 to 1.7 and 1.19 to 1.21). According to that scheme, two converters (for LV and HV use) and one EIS board, which is able to interface with both converters, were designed and several prototypes built. In order to better demonstrate the portability of the developed algorithms, characterization and on-line validation have been performed on another commercial fuel cell system, the Nexa Ballard Power Module. Furthermore, the analysis on LTFC in switched-off conditions was considered worth of attention for backup system as well as for other applications that may benefit from the diagnosis in such conditions (e.g. portable, automotive). A dedicated device was designed and built for the purpose of switched-off diagnosis; it is worth mentioning that the application of such a device to other FC technologies (e.g. SOFC) is straightforward. Thanks to these enhancements the industrial implementation of the diagnosis tool is flexible and affordable.

A list of the technical objectives achieved is reported below:

- Characterize LT and HT FC systems in different operating conditions.
- Test in climate chamber the LT PEMFC when switched-off.
- Provide experimental data and electrochemical impedance spectra for diagnostic algorithms development and validation.
- Design and manufacture the HV and LV DC/DC converters accounting to industry standards.
- Develop the EIS board to control both HV and LV converters and embed the spectrum analysis functions.
- Implement signal injection and data acquisition for the Impedance Spectroscopy analysis.
- Identify methodologies to infer on the FC status from model- and knowledge-based approaches for on-line application.
- Implement and validate model- and knowledge-based monitoring and diagnostic algorithms.
- Develop a technique to infer on the FC status when switched-off.
- Implement the interface for data exchange among converter, EIS board and FCS management system.
- Test the hardware and verify the whole assembly (FC & HW).
- Validate the monitoring schemes under normal operating conditions.
- Test the faults isolation to identify components and processes that operate under faulty conditions; infer on the stack status.
- Improve algorithms and system management.

The attainment of the technical objectives listed above has generated several outcomes with large benefits at industry and research levels; towards these goals some actions were taken to spread the knowledge gained thanks to the achievement of the following objectives:

- Disseminate the project idea via web-based technologies.
- Disseminate the results through scientific publications
- Organize two workshops to
 - discuss initially with scientific and industrial communities and then to

- present the EIS-based diagnostic tool and gather suggestions from international scientific and industrial communities.
- Implement student exchange programs among the partners.
- Initiate the process for results' exploitation towards production and commercialization.
- Participate to an international event (Hannover Fair 2014) for final dissemination activity.
- Results exploitation and project follow-up.

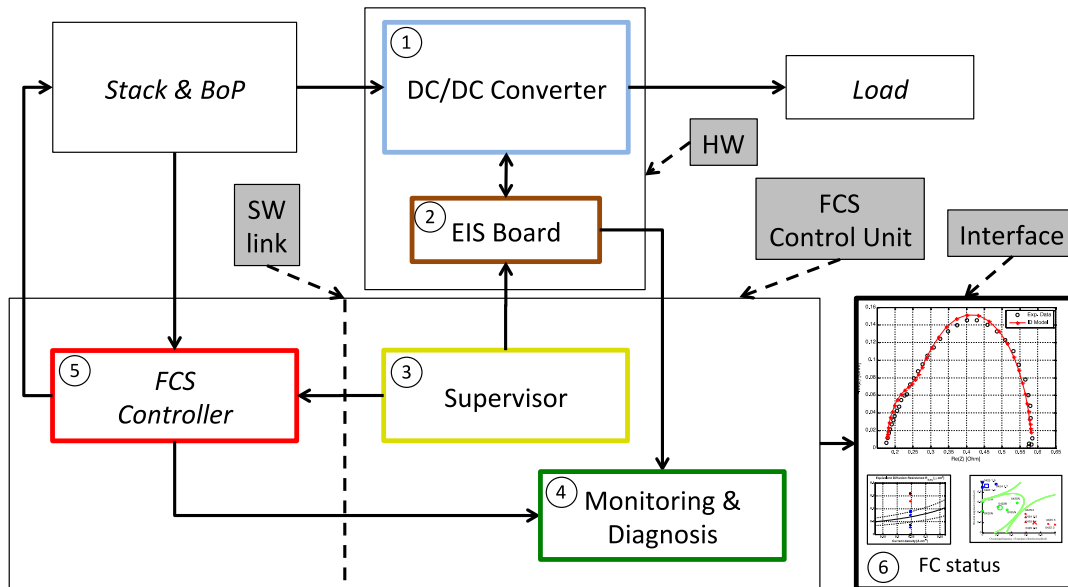

Figure 1.1 – Scheme of the D-CODE EIS-based diagnosis for a fuel cell system (stack & BoP). HW components: 1- DC/DC converter; 2-EIS board. Algorithms: 3-Supervisor; 4-Monitoring & Diagnosis; 5-FCS controller; 6-Interface. The SW link allows the connection among FCS Controller and algorithms.

1.3. Main S&T results

The D-CODE project structure was conceived on the basis of three main activities: i) the experimental characterization of LT and HT PEMFC systems to deepen the influence of control and BoP components on the EIS spectrum; ii) the manufacturing of hardware components (i.e. power electronics and FC system) with specific features so as to properly implement diagnostic algorithms based on EIS measurements; iii) the development of diagnostic tools exploiting the information embedded into EIS spectra in order to detect and isolate system components deviation from normal operating conditions. The project was structured into four research work packages (see figure 1.2), two more WPs were devoted to project management and to the dissemination of project results, respectively. The work package 2 (WP2) focused on the experimental activity to characterise both LT and HT fuel cell systems and to test diagnostic hardware and related strategies. WP3 was dedicated to the hardware design and realization of both the DC/DC power converters and the EIS command board. The activity of WP4 led to the development of the algorithms for the diagnosis. WP5 was finalised to the development of the management system to drive the DC/DC converter for EIS purposes and to improve the FCS control strategies taking advantages of the information gathered from the EIS-based diagnosis.

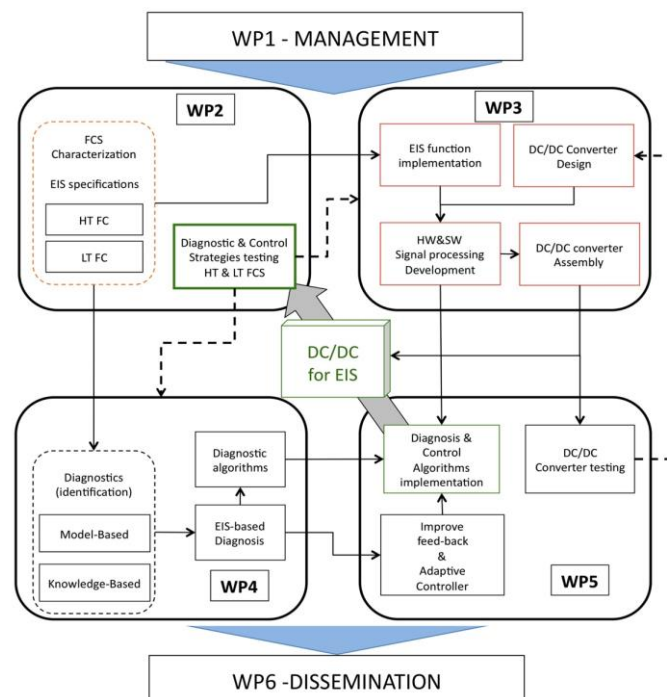

Figure 1.2 – Technical work packages. Dashed arrows show feedbacks from tests to improve DC/DC converter and diagnostic algorithms.

1.3.1. Project general description

1.3.1.1. Fuel cell systems characterization

A large number of characterization tests were conducted on the FC systems to increase data significance and repeatability; the main activity was conducted in the frame of the project, further data set were provided by Fraunhofer (ISE) and Aalborg University⁴. For low temperature FC a conventional and a modified Dantherm DBX2000 system were used, in the latter the BoP is electrically decoupled from the stack. The experimental campaign also investigated the effect of BoP components and grounding on the impedance measured on the stack. Furthermore, the modified system was tested in faulty conditions, i.e. some parameters in the on-board controller were changed to induce faults in the FC stack operation. The DBX2000 modified version was also

⁴ Cooperation with Fraunhofer Institute for Solar Energy in Freiburg (D) was set to exchange experimental data gathered on the same FC stack installed on the DANTH system; Aalborg University (DK) is partner of DANTH.

tested with the external high voltage DC/DC converter manufactured by CIRTEM (Figure 1.3-b) as well as the low voltage one purchased from MICROPI and built according to the design made by UNISA and shown in Figure 1.3-a. Both converters were coupled with the EIS external board designed and built by BITRON.

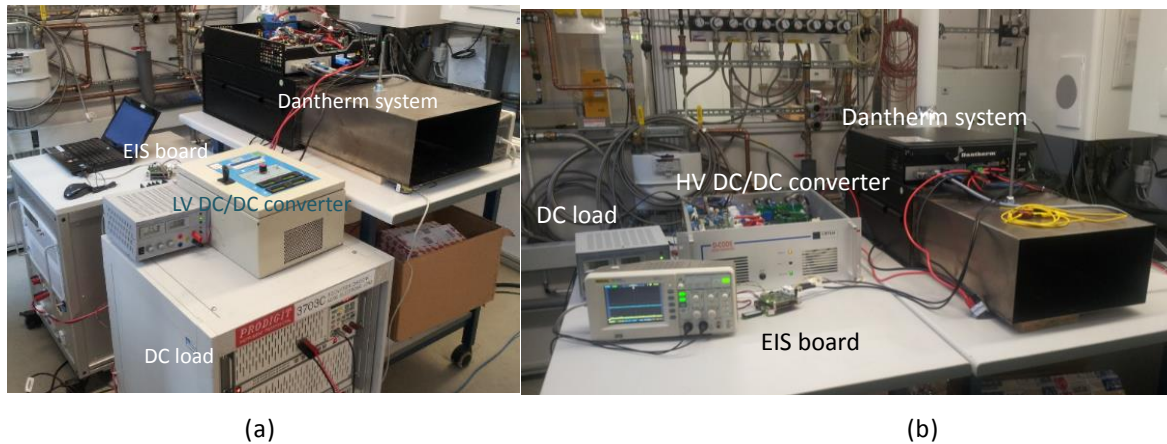

Figure 1.3 – Dantherm DBX2000 with external LV (a) and HV (b) converters plus the EIS board to record impedance spectra on the FC stack. For legend in (b) see Figure 1.1.

Dedicated tests were designed and carried out at EIFER to record EIS spectra on the stack using only the converter. An on-line validation procedure was developed and the diagnostic tools were validated with the system running in normal as well as in faulty conditions, while the converters were used to record EIS measurements on the stack. The quality of the result is very good considering the complexity of the configuration and the difficulty of carrying out impedance spectroscopy measurement on a relatively high power system, such as the DBX2000. Figure 1.4 reports the spectra measured through the EIS board at different loads for the assembly of Figure 1.3-a (i.e. DBX2000 modified and LV converter). The EIS were measured at low, mean and high currents; in Figure 1.4 the points at low frequencies are on the right side of each spectrum. At 5A the EIS exhibits some noise at low frequency, as the amplitude of the voltage AC current is very low and then very sensitive to any perturbation. At 40A, the EIS measurement has high quality on the whole range of frequencies. This is because the higher the current, the higher the signal-to-noise ratio.

In order to better demonstrate the portability of the developed algorithms, characterization and on-line validation were performed at UFC on another commercial LT fuel cell system, the Nexa Ballard Power Module. Figure 1.5 shows the hardware assembly with the same configuration of Figure 1.3-b, the HV converter is another prototype built by CIRTEM.

The high temperature PEMFC system assembled by Serenergy A/C was characterized at EIFER with a protocol similar to the one used for the low temperature Dantherm BDX2000 system. The tests were first performed with the control parameters default values and then repeated with different stack temperature, in turn, maximum and minimum values. The HT PEMFC system was also tested with the low voltage DC/DC converter coupled with the EIS external board and the stack impedance was measured (Figure 1.6).

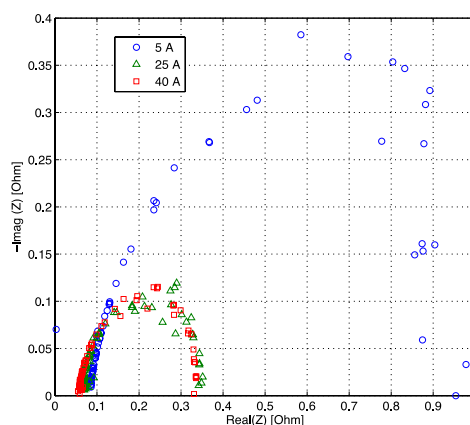

Figure 1.4 – EIS spectra recorded on the DBX2000 with the LV converter and the EIS board.

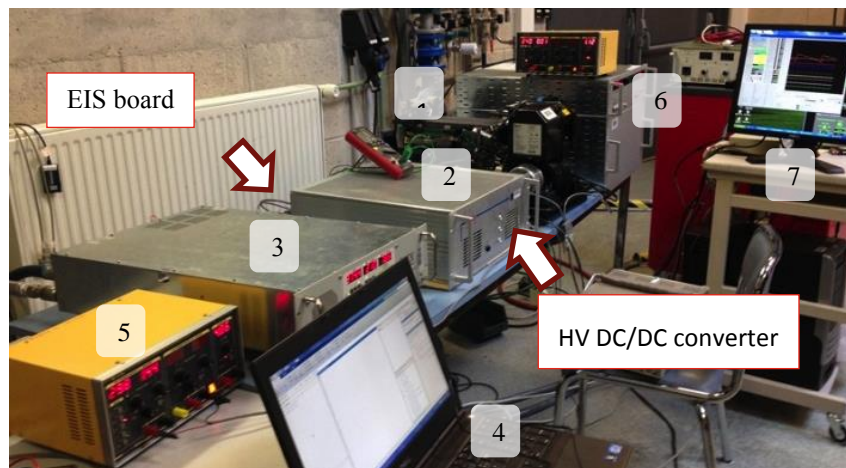

Figure 1.5 - Test bench at UFC. 1 - Nexa System; 2 – HV DC/DC converter; 3 - Electrical load; 4 - PC for EIS communication; 5, 6 - Power supply; 7 - PC for system monitoring.

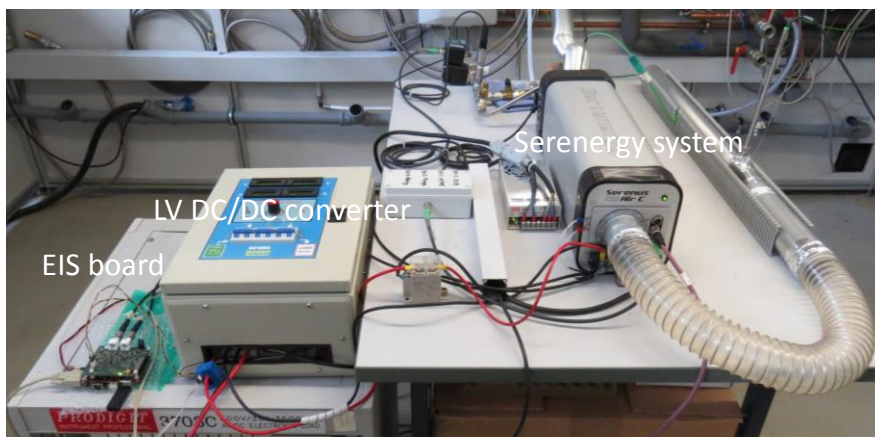

Figure 1.6 – Serenergy HT system with external LV converter and the EIS board.

To meet the requirements for the diagnosis of backup systems in switched-off condition, which is a critical task to guarantee system serviceability also for other FC applications, Dantherm in collaboration with the Aalborg University carried on the characterization in climate chamber of stacks in switched-off conditions. The new tests included not only humidity but also temperature cycles. To perform this activity UNISA designed an impedance analyser easily to embed into a DC/DC converter, which offers the possibility to perform EIS measurements system in switched-off conditions and detect the polymeric membrane humidification level. The Figure 1.7 shows the device developed by MICROPI connected with the FCS during the tests performed at EIFER.

The activity concerning the switched off analysis consisted in the measurements of the impedance on the DBX2000 modified system in switched off conditions at ambient temperature and humidity (see Figure 1.7). An example of the obtained results is given in Figure 1.8. The left diagram shows the impedance module versus the investigated frequency range. The right diagram shows the Nyquist plot of the same measurements. Both the results here presented are in accordance with the ones provided by Aalborg University (see Bidoggia⁵ et al.). Such results confirm the capability of the impedance analyser developed within the project and the feasibility of performing such a measure on the FC system for on field installations.

⁵ Bidoggia B., Koer S. K., Estimation of membrane hydration status for standby proton exchange membrane fuel cell systems by complex impedance measurement: Constant temperature stack characterization, International Journal of Hydrogen Energy 38 (2013) 4054-4066.



Figure 1.7 – DBX2000 standard system with external impedance analyser to measure the EIS spectra in switched-off conditions.

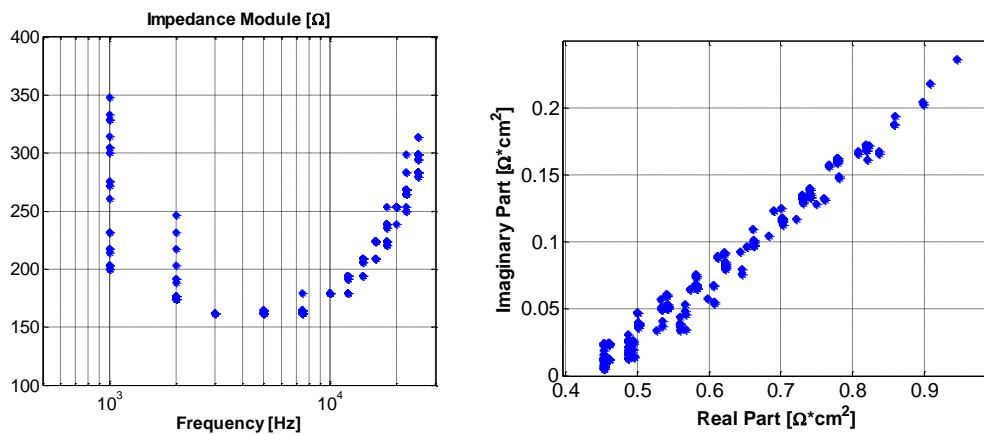

Figure 1.8 – Impedance module versus frequency and Nyquist plot for switched-off measurements on the DBX2000 modified system.

The table 1.1 shows a synopsis of the six FC arrangements (system and stack) investigated during the experimental campaign performed at EIFER and UFC; in the table the two supplementary sets made available from Fraunhofer ISE and Aalborg University are also reported for the sake of completeness. The cases shown in figures 1.3 through 1.7 are referenced into the relevant boxes; cross marks denote the other arrangements. It is worth mentioning that at the beginning of the project only two configurations were conceived for LT and HT FC, i.e. the LT DBX standard and HT Serenergy respectively.

Table 1.1 – Synopsis of the experiments performed on different FC.

Laboratory	EIFER	EIFER	UFC	EIFER	Aalborg	Fraunhofer
FC arrangement	DBX modified	DBX standard	Nexa Ballard	Serenergy	DBX stack	Ballard stack
Hardware						
Low Voltage	Fig. 1.3-a					
High Voltage	Fig. 1.3-b		Fig. 1.5	Fig. 1.6		
EIS board	Fig 1.3		Fig. 1.5	Fig. 1.6		
Spectrometer (OC)	X	Fig. 1.7			X	
Spectrum analyzer	X	X				X

1.3.1.2. Hardware design and manufacturing

The EIS board, developed by BITRON, is shown in Figure 1.9; this device is able to control both the HV and LV DC/DC converters, both shown in Figure 1.3. The EIS board output, where the variable frequency stimulus is produced by the firmware, is connected to either the voltage or current loops of the DC/DC converter, depending on the frequency range in which the stimulus lies. The two inputs to the EIS board are the stack current and voltage waveforms: they are processed, at each frequency of the generated stimulus, in order to produce an output file containing the real and imaginary parts of the stack impedance. During the signal processing, the firmware takes into account, among other things, the transient effect generated by the change of the frequency of the applied stimulus and the presence of noise, e.g. at switching frequency, affecting the two waveforms. The flexibility of the measurement is improved by the use of a configuration file, which is read by the EIS firmware as a first step of the measurement; it includes the list of frequencies (0.01 Hz - 2 kHz) to be analysed and the characteristics of the stimulus to be produced, frequency-by-frequency. The file is transferred to the EIS board by the supervisor (see element 3 of Figure 1.1) that runs on the FCS control unit. This allows to easily customizing the sequence of the measurement process.

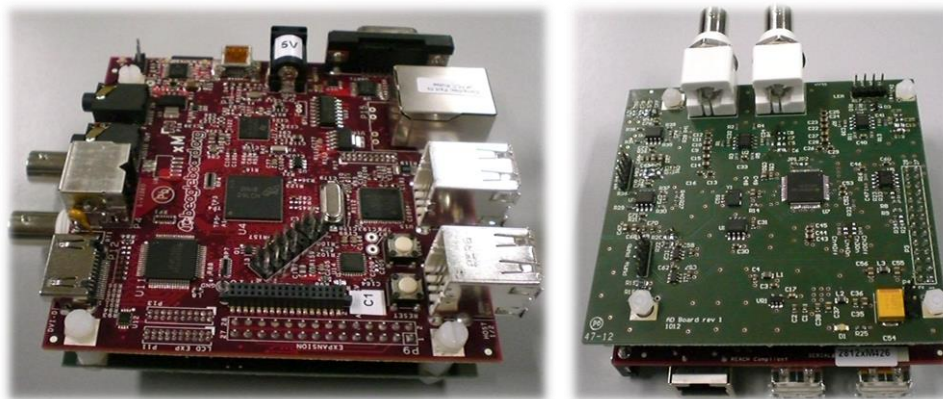

Figure 1.9 – EIS board. μ PC side of the board (left), signal injection and treatment layer (right).

The two DC/DC converters were developed in order to comply with different FC applications: stationary grid-connected, by means of the HV converter and backup, stand alone, by means of the LV converter. Both converters were designed to process the power produced by a 1.9 kW Dantherm system with a working voltage within the range 28-56V. As a consequence, the HV converter required a step-up topology, developed through a non-isolated solution in order to ensure the highest possible efficiency. The LV converter, which has to supply a 48V load, is based on a step-up-down SEPIC topology with coupled inductors. The project has also contributed to the development of a precision impedance analyser (see Figure 1.7) aimed at performing the EIS analysis of the stack in switched-off conditions. The analyser is able to cover the frequency range 1kHz-200kHz and can apply a sinusoidal stimulus from 1 mA to 1 A.

To perform the EIS measurements on a FC integrated in a complete system some guidelines were followed. Among others the main issues were those related to a proper interface and data exchange among Supervisor, Monitoring & Diagnosis modules and the FCS controller whose connections are shown in the Figure 1.1. Moreover, the impedance measure should not be influenced by any electrical component except the stack. A deep analysis of the measured spectra revealed several issues related to perform EIS measurements directly on a fully integrated fuel cell system. These issues were primarily caused by the fact that the fuel cell stack cannot be electrically isolated from the balance of plant and the system controller, since there is a circuitry hindering the EIS measurements of the isolated stack. Therefore, a modified fuel cell system had to be developed by Dantherm. The most difficult task in developing the modified system consisted in decoupling the DC/DC converter and the stack, as this modification required a major revision of the Dantherm DBX2000 embedded system software in order to make sure that the system was able to run reliably without compromising the basic safety of the system, in which the DC/DC plays a major role. This part of the work was inspired also by the need for having a system that complies with industrial standards. Other simpler solutions would have been possible for the purpose of testing only, but without achieving a complete validation at lab level. Now a solid study on that issue is available and will surely help during future actions oriented towards further implementation of the proposed methodology on field.

The schematic for the standard and the modified DBX2000 system is illustrated in Figure 1.10. From such representation it can be observed that the DC/DC converter was entirely electrically decoupled from the fuel cell stack (see the scheme on the right), and that the stack power was routed directly out through the main DC connectors of the control box. Also a separate stack current measurement had to be added.

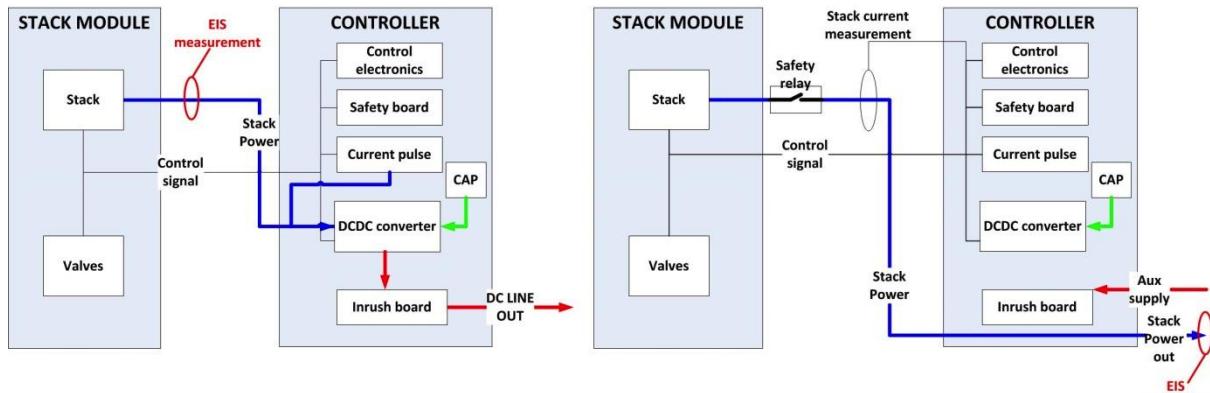

Figure 1.10 - Standard DBX2000 system, left; modified DBX2000 system, right.

In order to support the testing to be performed on the modified DBX2000 unit, it was chosen to develop a new monitoring and logging application for the system. The application communicates with the system via CAN-bus. The new monitoring application supported access to all system variables, and also supported logging these variables during testing on the system. On top of that, the application also provided a graphical interface, with the possibility of plotting charts for different system variables (see Figure 1.19).

For the purpose of integrating EIS enabled DC/DC converters, an architecture was developed, where the integration of the individual necessary devices was performed via a target PC, which served as the link between the fuel cell main controller, the DC/DC converter (with EIS board connected) and the diagnostic algorithms, with embedded EIS functionalities. The main advantage of this approach consisted in its flexibility in accepting codes or applications written in different programming languages. The solution would also virtually support any communication protocol chosen for communicating with the EIS-enabled DC/DC converter. Furthermore, the target PC had much more computational power compared to an embedded controller. The functional links among the components is presented on Figure 1.11. This scheme focuses more on signals communication if compared to that of Figure 1.1, which reports on the components functions.

On the DBX2000 system’s side the solution required a major modification to the software in the system’s embedded controller as well as a modification to the Labview monitoring and logging application for the system. Using this architecture it was possible to integrate the EIS enabled DC/DC converters as well as EIS measurement hardware developed in the project.

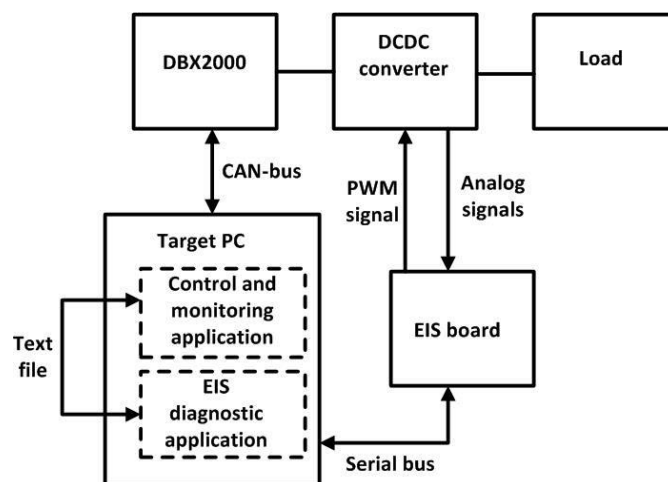

Figure 1.11 - Schematic of the implementation architecture for integration of the EIS-enabled DC/DC converter with the DBX2000 fuel cell system.

1.3.1.3. Diagnostic tools development and implementation

The model-based diagnostic tool developed by UNISA consists of two tasks: the identification of the parameters of an Equivalent Circuit Model of the stack, performed by exploiting the experimental spectra, and the detection and isolation of abnormal conditions via comparison of the identified parameters to their reference values. Such reference values are mapped as function of FC nominal operating conditions and modelled via black-box models specifically developed to estimate normal conditions values. The EIS spectra acquired in abnormal conditions were used for algorithm validation. An example of the online application of this diagnostic algorithm for DBX2000 system (see Figure 1.2) is shown in Fig. 1.12, where the values attained by one model's parameter (e.g. the membrane resistance) are compared with the nominal ones. In this figure, the coloured areas highlight the parameters deviation (abnormal operations) at different operating currents. The isolation process is then performed making use of a signature matrix, which accounts for the information brought by four ECM model parameters (see the bottom side of the figure).

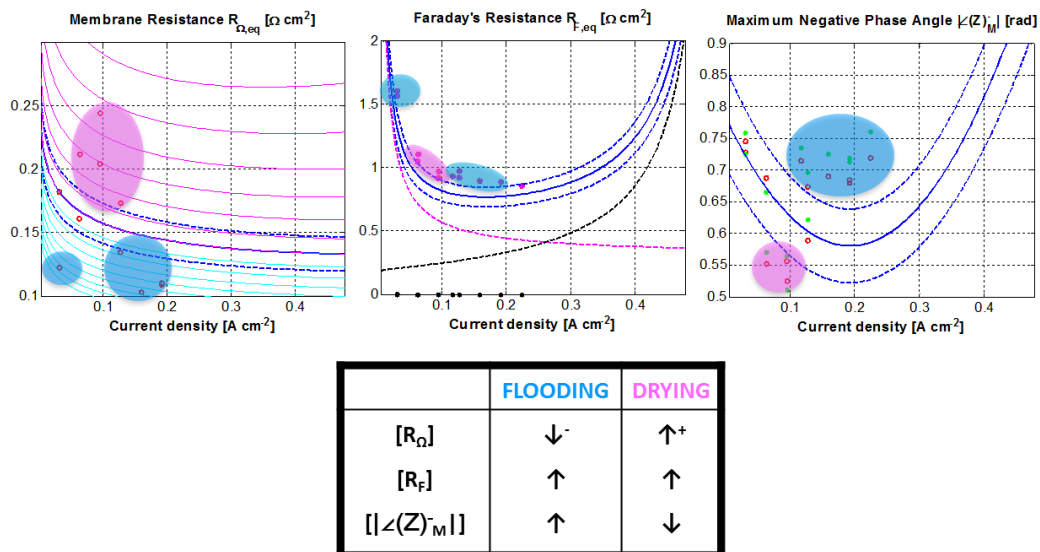

Figure 1.12 – Model-based diagnostic algorithm application on the DBX2000 System. On the top the deviation of the ECM model parameters (magenta and cyan area); on the bottom the signature matrix developed to isolate flooding and drying faulty operations.

A detailed scheme of the on-line diagnostic procedure was conceived, with all the required phases, from the fault detection to the isolation. Moreover, among all the possible faults taken into account in a preliminary analysis, only drying and flooding were considered as the ones currently inducible for a validation of the proposed algorithm. Figure 1.13 illustrates the comprehensive model-based diagnostic tool proposed and developed by UNISA.

For the development of the aforementioned ECM parameters models, the knowledge of current load and stack temperature is essential. This requirement led to the development of a specific communication protocol between the UNISA algorithm and the DBX2000 system control software, so as to acquire the current and temperature measurements for each EIS spectrum. Analytical regressions have been computed for the system state variables (i.e. stack voltage, stack temperature and blower power) estimation in normal operating conditions. These regressions are essential to perform a plausibility check to understand if the system variables are at the expected operating condition.

To retrieve the essential information from the EIS board, the UNISA diagnostic algorithm reads from a text file the EIS measured variables (i.e. frequency, impedance real part, imaginary part, module and phase). These information are treated in order to identify the spectrum and compute the ECM parameters values.

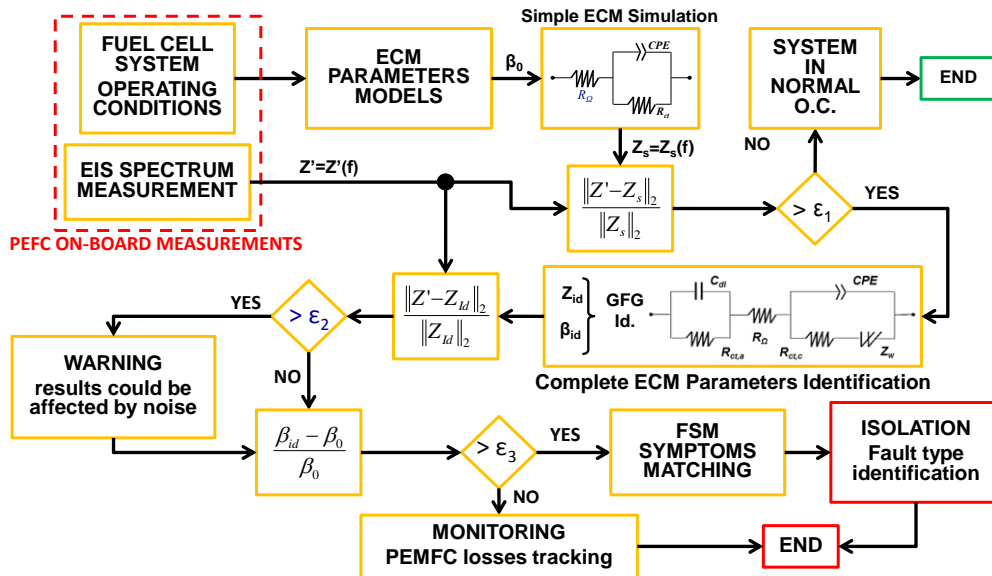

Figure 1.13 – Equivalent membrane resistance model function of current density, stack temperature and membrane water content.

Two knowledge-based diagnostic algorithms were developed by UFC: a fuzzy-logic one and an advanced neural-network based one. The former consists of a Fuzzy Clustering algorithm for automatic learning from experimental data and a Fuzzy Inference System (FIS) for decision-making. It was validated online on two different LT stacks (see Figures 1.3 and 1.5). The Fuzzy Clustering algorithm consists of four steps: feature extraction and selection, fuzzy clustering, and diagnostic rule design, showed in Figure 1.14, where the upper part is related to the off-line training and the lower part to the online testing. Since it combines both fuzzy clustering and fuzzy logic, it is thereby called “double-fuzzy” methodology.

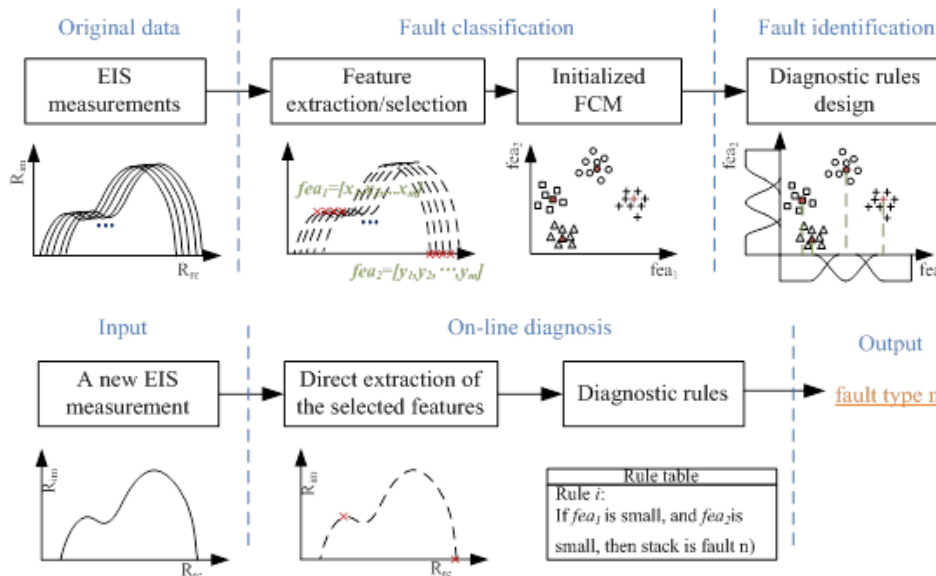

Figure 1.14 - Illustration of double-fuzzy diagnostic methodology: off-line (upper) and on-line (lower).

Another diagnostic algorithm was developed, it is based on liquid state machine (LSM) which is an advanced architecture evolved from the traditional recurrent neural network. The main idea is to create an internal network randomly and keep the connections fixedly; the only part to be trained is the output weights. The main structure is shown in Figure 1.15. The stimulated stack voltage at a low frequency is used as the neural network’s input and the health status is used as its output. The main considerations of utilising stimulated stack voltage as inputs are: (1) the stack voltage is a credible reflection of FC degradation; (2) when stimulated by an

AC sinusoidal current, it includes also the information about ac impedance, which is believed to be discriminant in diagnosing flooding and drying.

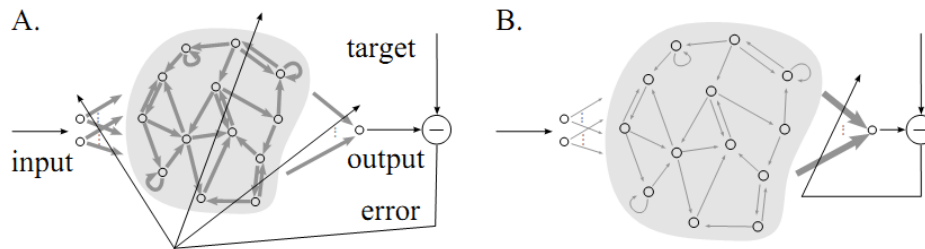

Figure 1.15 - Recurrent Neural Networks (RNN, left; right: LSTM).

The experimental results demonstrate the algorithms high accuracy rate (100%), computational efficiency (less than 5s), easy implementation and good portability. Besides the LT type, the methodology is verified on the HT stack (Figure 1.6), which further shows its capability for fault diagnosis of PEMFC stacks regardless LT or HT types. Figure 1.16 shows an example of UFC algorithm for fault-diagnosis application to NEXA System. Three different operating conditions were analysed on the NEXA system (normal, air starvation and air surplus) and the stars represent the location of each operating point with respect to the three considered regions (i.e. clusters).

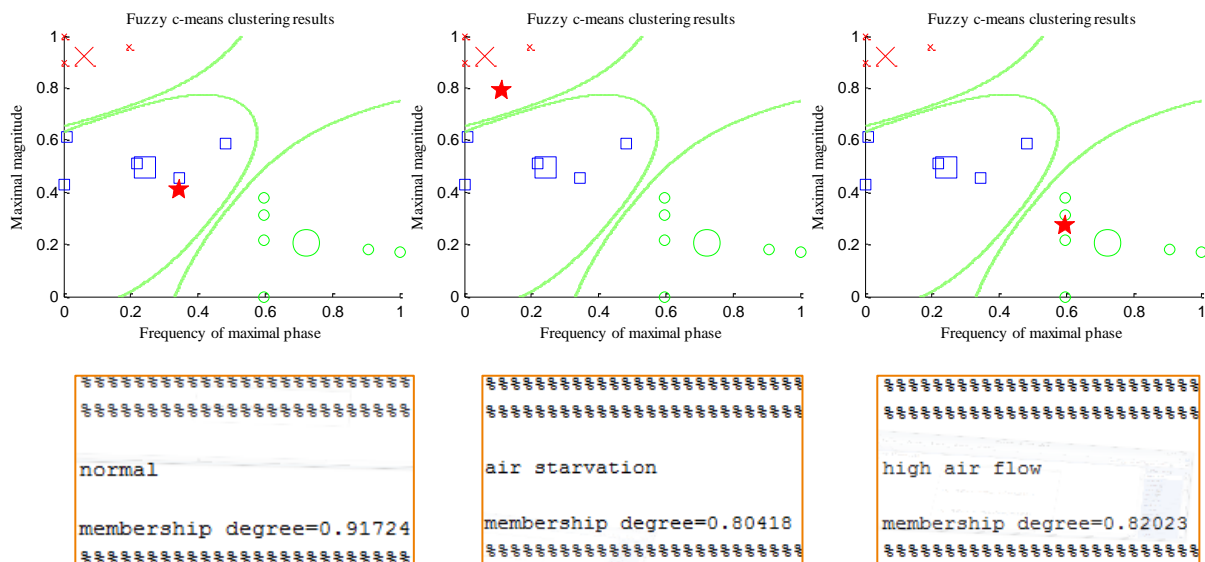

Figure 1.16 - UFC diagnostic result based on NEXA system coupled with HV DC/DC converter and EIS control board (normal, low and high flow conditions).

The diagnostic methodology proposed by EIFER is a data-based approach. First, a set of statistical reliable data in different conditions (i.e. flooding, drying and normal) needs to be taken. Second, the conditions of the fuel cell are defined as an output and associated with the referring states. Third, an Adaptive Neural Fuzzy Interference System (ANFIS) is trained with the prepared data set. The Adaptive Neural Network (ANN) teaches a Fuzzy Interference System (FIS) with a predefined structure and compares the output of the FIS with the known output of the data set. One run of the ANN algorithm is called an epoch. During this training phase, several epochs are required for proper results of the FIS. In general, a data set is randomly divided in sets for teaching the system and sets for testing the trained FIS. The error between the known output and the output of the FIS can be used as an assessment of the tool performance. Ultimately, the trained FIS represents a model of the states inside the cell. It is worth remarking that any data-based approach can only identify conditions with noticeable differences in the measured data sets. Another important point is to avoid and filter noise as much as possible. For that reason, different approaches for data pre-treatment were investigated. The algorithm scheme is presented in Figure 1.17. In the Figure 1.18 the results for the NEXA system are reported showing three cases, namely normal, drying and flooding operations for the NEXA System running at 10 A.

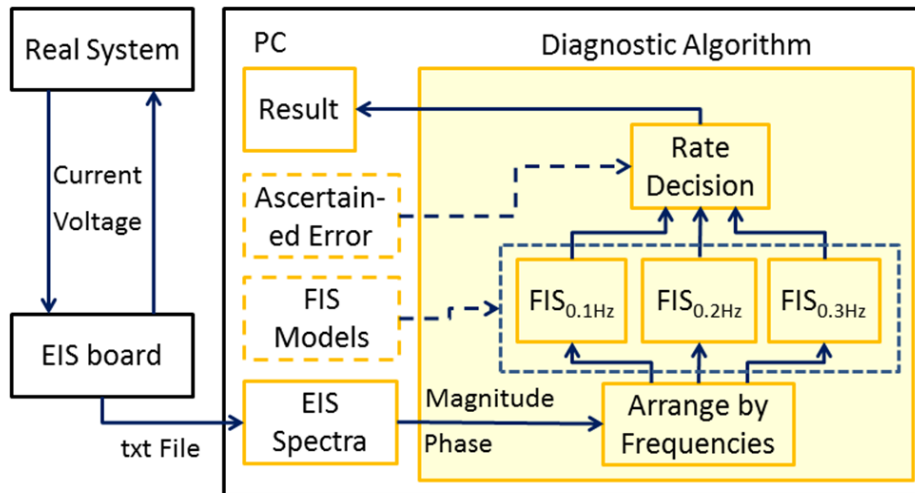

Figure 1.17 – Scheme of the EIFER diagnostic algorithm.

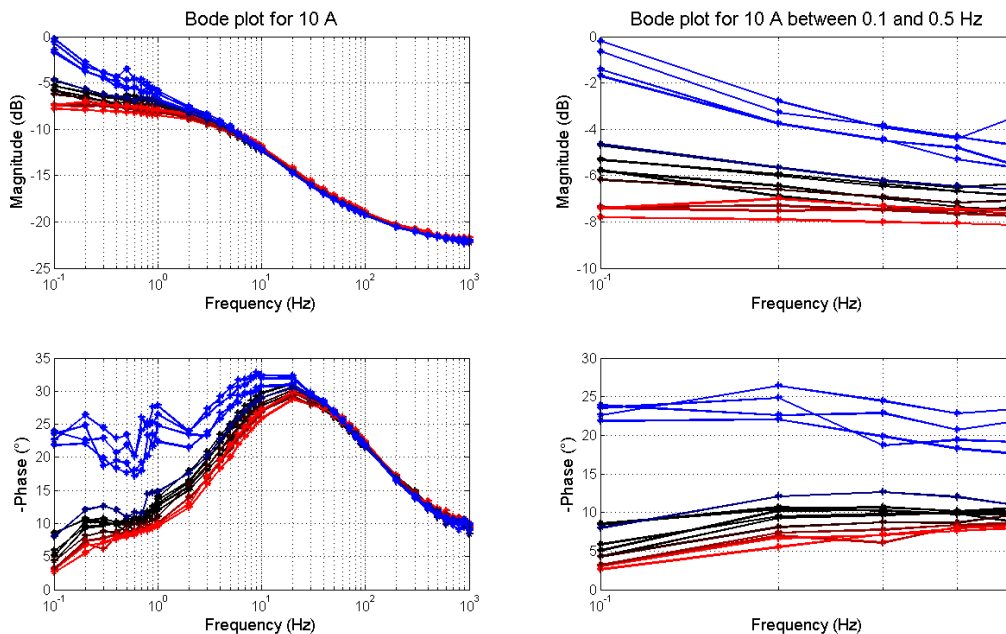

Figure 1.18 – Example of Bode plots exploited by the knowledge-based diagnostic algorithm developed by EIFER. The bode plots refer to Nexa System at 10 A and different conditions (drying out/red, flooding/blue and normal/black).

In Figures 1.19, 1.20 and 1.21, the interfaces (see item 6 of Figure 1.1) of the three diagnostic tools developed by UNISA, UFC and EIFER are shown. It is worth remembering that the diagnostic tools developed by the D-CODE project may detect the following abnormal operations:

- Air starvation
- Fuel starvation
- Flooding
- Drying

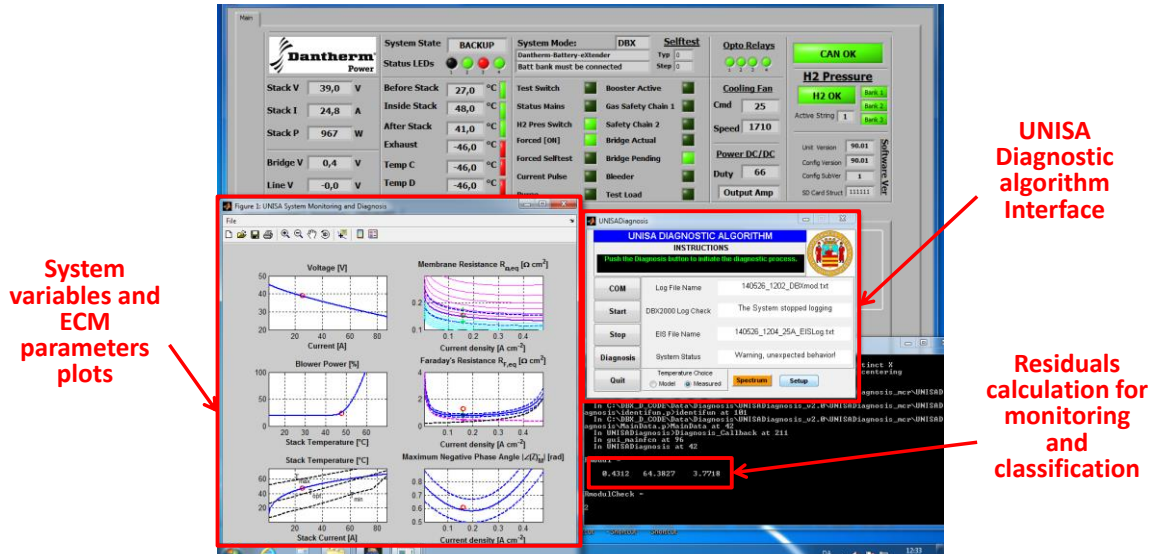

Figure 1.19 - Schematic of the implementation architecture for online integration of the EIS-enabled DC/DC converter with the DBX2000 fuel cell system.

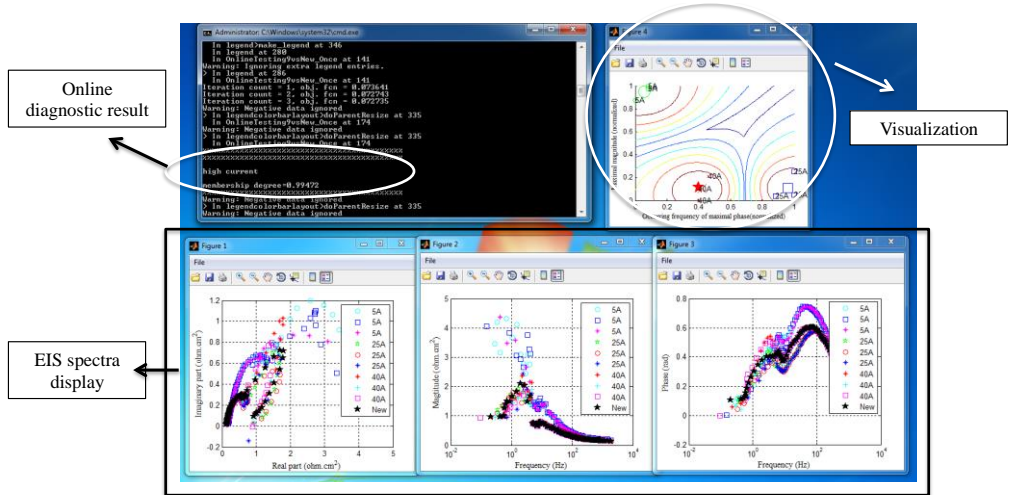

Figure 1.20 –UFC diagnostic algorithm based on fuzzy logic applied online with high voltage DC/DC converted and EIS board implemented.

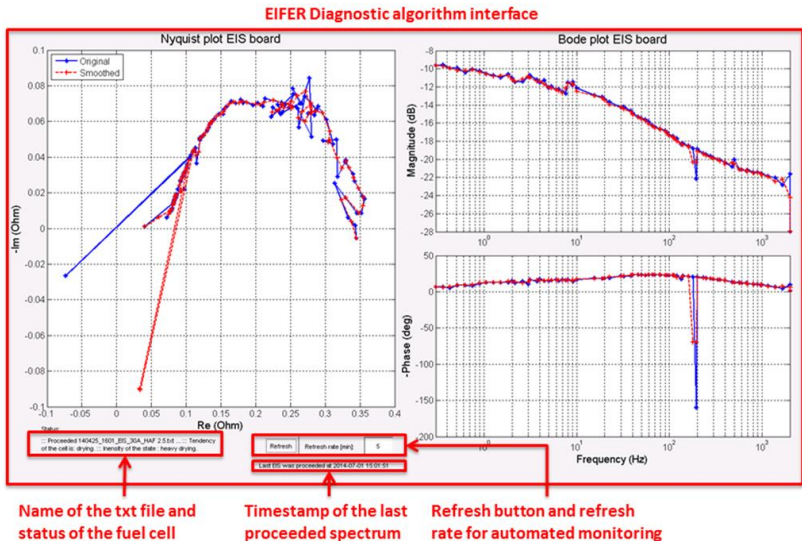

Figure 1.21 – On-line EIFER diagnostic algorithm application.

1.4. Expected impact

1.4.1. Expected outcomes and target achieved

With the aim of analysing the future impact of the results achieved by the Project D-CODE, it is worth describing its outcomes with respect to those envisaged in both annual and multi-annual implementation plan documents (AIP and MAIP)⁶.

The right column of table 1.4.1 reports the synthesis of the results, whose list is gathered from the objectives achieved (see section 1.2.3), re-arranged consistently with the viewpoint of the 2009 annual implementation plan expected outcomes (left column)⁷.

Table 1.4.1 – Comparison between call expected outcomes and project results.

Topic SP1-JTI-FCH.2009.3.3: Operation diagnostics and control for stationary power applications	
Topic Expected outcomes	D-CODE results
<i>Novel diagnostics to identify potential failures, including in-operation diagnostic tools for cell/stack</i>	The project has achieved the successful implementation of the EIS, which is considered the most reliable diagnostic tool for FC. D-CODE has demonstrated how transpose EIS-based diagnostic from lab scale to on-field applications. FC failures have been identified precisely and therefore the methods proposed are competitive with respect to conventional diagnostics.
<i>FC-unit level failure sensitivity matrix</i>	A failure sensitivity matrix was not a direct objective of the project. However the EIS-based diagnosis may be used to set the work for an on-field study for FC monitoring towards the development of failure sensitivity matrix.
<i>Improved prediction and avoidance of failure mechanisms</i>	The three diagnosis methods developed are accurate enough to guarantee reliable faults detection for failure avoidance. Moreover, the reliability might be improved by the implementation of the three algorithms to provide simultaneously diagnosis output. That is possible since the same measure (EIS) is processed with different techniques.
<i>Development of strategies for recovery of cell and stack performance</i>	The EIS-based diagnosis may support the feedback or adaptive controllers through quantitative data on the basic electrochemical phenomena occurring into the stack.
<i>Tools for improved field diagnostics and services</i>	It has been proven that the on-board EIS-based diagnosis proposed improves the effectiveness of FCS monitoring. Once implemented on-board the diagnostic tool will improve FCS serviceability thanks to its accurateness during real operations.
<i>Control of stationary fuel cells systems in integrated generation environment to deliver low emissions and high network efficiencies</i>	The accurate FCS state identification achievable with on-board EIS monitoring will allow implementing tight feedback/adaptive controllers; this in turn will result in more precise control actions with the attainment of optimized performance (efficiency and emissions).

With respect to the RTD priorities of the FCH-JU 2009 call, the project results will have a remarkable impact towards the key objective of “... placing Europe at the forefront of fuel cell and hydrogen technologies

⁶ The original documents are available on the web site of the FCH-JU (<http://www.fch-ju.eu>), section documents - IV RTD agenda.

⁷ The text in Italic has been extracted from the AIP and MAIP documents.

worldwide and enabling the market breakthrough of fuel cell and hydrogen technologies, thereby allowing commercial market forces to drive the substantial potential public benefits ...". Indeed, the proposed diagnostic tool represents a step forward to enhance the performance of FC systems, guarantees the advancement of the technology and improves the commercial competitiveness of the systems that might embed it. Although developed for PEM, the diagnostic tool might be extended to any FC technology through the methodological process outlined by D-CODE. Looking at the industrial scenario of the FC market, the proposed solution contains several technological innovations (e.g. on-board EIS, model- and knowledge-based diagnostic algorithms) that neither the EU industries nor their non-EU competitors have yet in the portfolio.

Moreover the AIP focused on applied research activities "*... directed towards developing components and sub-systems with improved performance, durability and cost for all three technologies in order to achieve system application readiness ...*". The project's approaches, methodologies and applications belong to the broad area of applied research; this complies with the objective of advancing the actual technology through the enhancement of components (here component means either physical device or software) that are able to improve FCS. The objectives achieved have a direct impact on both performance improvement and durability; the former is linked to the capability of forecasting FC status thanks to the precise knowledge of the stack status via EIS monitoring, whereas the latter deals with the correct and timely detection of faults, whose knowledge may support the controller to activate precise countermeasures to maximize the system readiness.

The analysis of the results summarised above permits to state that the diagnostic tool designed, built and tested during the project fits within the boundaries set by the multi-annual implementation, whose one objective was the achievement of "*... new or improved materials as well as reliable control and diagnostics tools both at component and system levels ... directed towards developing components and sub-systems ... leading to step change improvements over existing technology in terms of performance, endurance, robustness, durability and cost for all technologies ...*".

The results and the objectives just reviewed deals with technical issues whose impact spreads towards social and economic areas. Once implemented on-board of FC, the diagnostic tools will advance their performance contributing to increase the overall effectiveness of these energy conversion systems, as well as to make them more attractive. Indeed the solution proposed has a positive impact on the operational costs because of its effects on PEM stacks reliability and lifetime, which can be improved thanks to the monitoring and diagnosis tools. These benefits might be gained by all PEM applications (CHP, APU, backup) thanks to the flexibility of diagnostic tool, which can also be implemented on other FC technologies (e.g. SOFC) by following the methodological steps proposed. Moreover, the electrochemical impedance spectrum can be measured via low cost hardware, which was built following industrial standards. These points represent further advantages to reduce development costs and consequently purchasing price. Therefore, future commercialization can be easily promoted increasing the number of FC systems.

Finally all the above technical and economic advancements achievable through the implementation of the diagnostic tool will increase the diffusion of the fuel cell with an indirect impact on the major environmental issues.

1.4.2. Dissemination

The results of D-CODE have been disseminated through different ways to increase the awareness of both the scientific and industrial communities. The communication strategy was based on three pillars: workshops, website and scientific communications (i.e. publications).

According to the project schedule, two workshops were successfully organised. The former was held on June 2012 during the French Research Network on Fuel Cells meeting. More than 50 researchers attended the two special sessions on FCS diagnosis, whose 9 lectures were given by the invited speakers. The coordinator's keynote speech was given during a plenary session with about 250 attendants (see Figure 1.4.1, left). A second workshop was held in Karlsruhe, Germany (April 2013). It was organized in the framework of the Conference FDFC (Fundamentals and Developments of Fuel Cell) and gathered 81 attendants (see Figure 1.4.1, right). Eleven presentations were delivered, followed by interesting comments and questions from the audience. The last event organized focused on the dissemination towards industrials. The D-CODE results were presented at the Hannover Fair in April 2014, during 1 week (see the pictures of Figure 1.4.2). The purpose was to show in a booth the hardware (i.e. the fuel cell system, the new converters, the control board, the diagnosis algorithm). The project's booth was located in the group exhibit "Fuel Cell and Battery Exhibition", the Europe's largest

exhibition in this field. In the booth, the hardware developed in the project was exhibited and the results presented on posters (see Figure 1.4.3). Brochure and flyers were also distributed to the visitors. Sixty contacts were established with visitors coming from 20 different countries. A presentation of the results was done by the coordinator in the technical forum, the video is available on the Fair website as well as on “YouTube” (see the bottom right corner of the Figure 1.4.3). The participation to the Fair was a valuable opportunity for the consortium to meet several important actors in hydrogen and fuel cell activities.

The official website of the project is available at the URL <https://www.d-code-jti.eu>. On the same website all main achievements of the project are presented to disseminate the results and to increase the awareness of the industrial and research communities about the D-CODE project. The website has been regularly fed with the main achievements of the project: photos of the developed hardware, public milestones of the project, information on the events organized, references of the scientific publications co-authored by the partners and public documents available for downloading. As of July 12rd 2014, a search on the Google database using the keys sequence “on-line EIS diagnosis PEM fuel cell” provided a list of relevant links and the project D-CODE was in the first page at 5th rank.



Figure 1.4.1 – First (2012) and second (2013) project annual workshops held in Belfort and Karlsruhe.



Figure 1.4.2 - DBX FCS connected to the HV DC/DC Converter on display at the Hannover Fair 2014 (left); Prof. Marie-Cécile Péra explains to visitors the equipment at the Hannover Fair 2014 booth (right).



Figure 1.4.3 – Images of the posters displayed at the Hannover Fair and at the right bottom a snapshot of the YouTube Video with the presentation given at the Hannover Fair.

To disseminate the scientific knowledge along the project, seven papers have been published through different ways. First, two articles have been published in a major journal which is International of Hydrogen Energy (Impact Factor: 3.55). Four papers have also been presented in major conferences publishing proceedings (3 in FDFC 2013, 1 in IEEE-IECON 2013). An article is in final revision in another high level journal, Journal of Power Sources (IF: 4.675), and should appear in autumn 2014. The list of the papers is reported below:

1. Zhixue Zheng, Raffaele Petrone, Marie-Cécile Péra, Daniel Hissel, Mohamed Becherif, Cesare Pianese, Nadia Yousfi-Steiner, Marco Sorrentino, “A review on non-model based diagnosis methodologies for PEM fuel cell stacks and systems”, International journal of hydrogen energy, vol.: 38, number: 21, pages: 8914-8926, DOI: 10.1016/j.ijhydene.2013.04.007.
2. Raffaele Petrone, Zhixue Zheng, Daniel Hissel, Marie-Cécile Péra, Cesare Pianese, Marco Sorrentino, Mohamed Becherif, Nadia Yousfi-Steiner, “A review on model-based diagnosis methodologies for PEMFCs”, International journal of hydrogen energy, vol.: 38, number: 17, pages: 7077-7091, DOI: 10.1016/j.ijhydene.2013.03.106.

3. Angelo Esposito, Bastian Ludwig, Cesare Pianese, Soeren Boedker, "Experimental Characterization of a PEMFC System with Electrochemical Impedance Spectroscopy", 5th Fundamentals & Development of Fuel Cells Conference (FDfC), April 16-18, 2013, Karlsruhe, Germany.
4. Zhixue Zheng, Marie-Cécile Péra, Daniel Hissel, Mohamed Becherif, "Diagnosis of proton exchange membrane fuel cell (PEMFC) stack based on fuzzy clustering", 5th Fundamentals & Development of Fuel Cells Conference (FDfC), April 16-18, 2013, Karlsruhe, Germany.
5. Raffaele Petrone, Zhixue Zheng, Daniel Hissel, Marie-Cécile Péra, Cesare Pianese, Marco Sorrentino, Mohamed Becherif, "Implementation of EIS measurements on an embedded commercial system", 5th Fundamentals & Development of Fuel Cells Conference (FDfC), April 16-18, 2013, Karlsruhe, Germany.
6. Zhixue Zheng, Raffaele Petrone, Marie-Cécile Péra, Daniel Hissel, Mohamed Becherif, Cesare Pianese, "Diagnosis of a Commercial PEM Fuel Cell Stack via Incomplete Spectra and Fuzzy Clustering", 39th Annual Conference of the IEEE Industrial Electronics Society (IECON) November 10-13, 2013, Vienna, Austria.
7. Zhixue Zheng, Marie-Cécile Péra, Daniel Hissel, Mohamed Becherif, Kréhi-Serge Agbli, Yongdong LI, "A double-fuzzy diagnostic methodology dedicated to on-line fault diagnosis of PEMFC stack", Journal of power sources, February 2014 – Under revision.

At educational level 3 PhD students were involved in the project, moreover several Bachelor and Master students worked on the D-CODE topics. Zhixue Zheng (UFC) has prepared her Doctoral thesis in the framework of D-CODE. She defends her PhD thesis in September 2014, at UFC, Belfort, France in front of an international jury (French, Spanish, Swiss and Chinese members in the jury). Raffaele Petrone (UNISA) was supervised by UNISA and UFC and defended its Doctoral thesis on his work developed in the framework of D-CODE. He's currently performing a post-doc at UFC on a related subject. Pierpaolo Polverino (UNISA) focused its Doctoral work on SOFC, his experience on software and hardware integration allowed the development of the fault identification algorithms and its interfacing to PEMFC; he's now with UNISA as research assistant. Some students at Bachelor and Master levels developed their final work in the frame of the D-CODE project. The teaching staffs of UFC and UNISA deliver several courses on energy conversion technologies for undergraduate, graduate students, summer schools and tutorials. The D-CODE results will feed the fuel cells sections of these courses.

The dissemination of the results will continue after the end of the project as a part of the main communication activity of each partner, either research institution or industry. Indeed further scientific publications will be issued as follow-up of the work done during the project. It is envisaged that the results achieved will be further checked and improved to make them interesting for publication in International Journals. Moreover, the work performed has set solid bases on which further research work can be built leading to more publications as well as other research projects, which in all cases will acknowledge the role and the results of D-CODE. Academic partners will include in their teaching activity the study performed within D-CODE and the experience made. This will spread out at a larger extent the concepts of diagnosis as well as of the on-board application of EIS. At industrial level the work performed is part of the technical know-how of these partners, which may also add the developed hardware in their catalogues. Therefore, several dissemination actions will be also taken as part of the normal communication strategy of each partner. Moreover, other dissemination actions could be performed if requested by the FCH-JU (e.g. annual review events).

1.4.3. Exploitation of results

The project D-CODE has demonstrated the feasibility of using a low-cost EIS-board in conjunction with a DC/DC converter to perform EIS-based PEMFC diagnosis. This enables fuel cell systems to be monitored during operation or in standby mode, contributing to an improvement in their reliability without adding excessive cost. The DC/DC converters and the EIS board are production-ready devices. The future step is to further develop the application to take it out of the laboratory and into wide scale field testing, with a view to making the solution commercially available for a wide variety of fuel cell applications.

The consortium looks forward to exploit both hardware (converters, EIS board) and software (diagnosis algorithms) outcomes. Limited but necessary improvements are required to implement the tool for on-field use. The TRL achieved by D-CODE ranks the level 4 (technology validated in lab); TRL5 (technology validated in relevant environment) can be easily achieved, even TRL6 (technology demonstrated in relevant environment)

could be reached as well. Therefore a follow-up would focus on the improvement of the proof of concept towards on-field application to valorise the project results. Moreover both hardware and diagnostic algorithms could also be easily exploited at laboratory level with an effective reduction of equipment costs; this would require some changes in the implementation and in the hardware to comply with laboratory standards. Future work may support the research towards the study of other faults or failures to be isolated on-board by processing the impedance spectrum via either model- or knowledge-based approaches. Further actions are also required on the methodological side to develop an integrated experimental and computational framework for the design and manufacturing of EIS-based diagnosis tools. This would simplify the implementation on any PEMFC and may reduce the effort required for diagnosis algorithms identification and customization. An *ad hoc* activity might be settled for stack and system identification under mimicked faults for the development and testing of diagnosis algorithms.

The project's outcomes will serve as a basis to provide increased knowledge on the potentialities offered by advanced diagnosis, on-field deployable diagnostic tool and related hardware. It is worth remarking the close interaction between diagnosis and state-of-health evaluations as well. The availability of advanced algorithms (i.e. EIS-based) for the condition monitoring of FC represents a first step towards the implementation of advanced control, as well as effective prognosis algorithms. Future cooperation among the partners will support significant research on PEM lifetime via advanced control (either feedback or adaptive) and the development of tools aimed at evaluating system residual lifetime as well as expectable end-of-life performance. Apart from the application to other FC technologies (i.e. SOFC), the developed methodologies and hardware can be also extended to other electrochemical devices (e.g. battery).

The D-CODE partners will exploit the know-how gained during the project along three main lines of action, namely at industrial, research and educational levels, either within cooperative or autonomous work. Cooperative activity will be exploited by some partners potentially interested in the implementation of the EIS on commercial FC. Notably DANTHERM Power may lead a group to continue the development of the actual tool for the implementation on board of their systems. In that case the work will focus on processes, methodologies and standards at industrial level to make the diagnostic tool an effective instrument to improve performance and increase the FC lifetime. This will guarantee a better competitiveness and may represent a reference for the entire community, thus fostering a widespread implementation of advanced diagnostic tools.

On the power electronics side BITRON could continue the development of the EIS board and include it in their catalogue. In such a case, the board may be purchased by customers wishing to use a low cost instrument capable of injecting sinusoidal waveforms for the purpose of analysing the dynamic response of other electrochemical devices (e.g. batteries). Electrical devices can also be considered for the dynamic response at frequencies below 1 kHz.

CIRTEM could exploit the experience achieved in the design and building of high voltage DC/DC converters for several applications other than fuel cells.

Moreover, the entire diagnostic tool (EIS board, converter and algorithms) might be installed at lab scale as low cost spectrometer. Moreover, the algorithms proposed by UNISA, UFC and EIFER are ready for on board implementation of any spectrometer and could be implemented in software packages for the EIS data analysis and FC diagnosis.

All research partners will continue the researches started in the project; the exploitation of the results will continue towards both basic and applied research leading to further cooperation opportunities. As a first step, a common paper between the D-CODE partners will be coordinated by UFC in order to synthesise the results obtained with the algorithms developed by UFC, UNISA and EIFER.

1.5. The project public website

The D-CODE website was structured and implemented in the first part of the project and mostly used for the data exchange among the partners through the intranet section. During the project, as soon as new outcomes were made available and the main dissemination events were closed, the website was updated with new information. Below is reported a summary of the website structure then the description of the actions made during the second period is given.

The website was implemented by EIFER and is hosted on their server. The web address is <https://www.d-code-jti.eu>. It's divided into two main sections, namely, access-free and intranet area, which is restricted to the project partners only. Overall, the web manager registered about 3000 contacts. The Figure 1.6.1 is a snapshot of the welcome page.

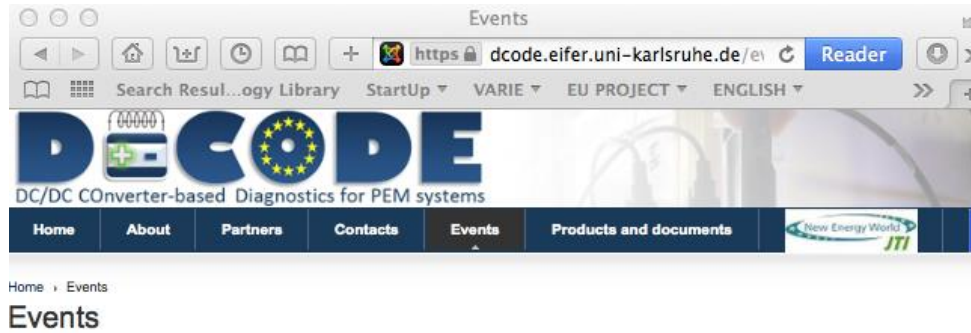

Figure 1.6.1 – Snapshot of the welcome page of the project website.

Public webpage

The public web page has 6 menu tabs (Home, About, Partners, Contacts, Events and Products & Documents). The sections Events and Products & Documents were updated continuously during the second period to add the information about the main dissemination events and the documents describing the results of the projects. The website has been regularly fed with the main achievements of the project: photos of the developed hardware, public milestones of the project, information on the events organized in the framework of the project, references of the scientific publications co-authored by the partners and public documents available for downloading.

In the Figure 1.6.2 the snapshot of the upper part of the section event is shown, here the main information on the participation to the Hannover Fair (April 2014) are reported. Several URLs connect to other website with further information on the hosting event. A list of the main documents describing the project and its results is available in the section documents as shown in the Figure 1.6.3.



LIST OF THE D-CODE DISSEMINATION EVENTS

Final Dissemination event - Hannover Fair

The D-CODE Consortium had a booth at the Hannover Fair held in Hannover (D) from 7th to 11th of April 2014. The hydrogen, fuel cells and battery exhibition is the Europe's largest exhibition and is part of at the Fair, which hosted about 200.000 visitors and 5000 exhibitors. For details on the Fair see <http://www.h2fc-fair.com/index.html>.

This was the **final dissemination event**, the partners presented their single work for the development of the EIS-based diagnostic for PEM FC. On Friday the 11th, the coordinator gave a presentation of 30 minutes showing the hardware built, the algorithms developed and the final results achieved, the video of the presentation is available on the [Fair website](#) or on [youtube](#).

Many visitors were interested in the diagnostic tool, which allows to perform reliable analysis of the actual system status making use of the EIS. Below some pictures taken at the D-CODE booth (C35). You may download more pictures form the Hannover Fair [website](#).

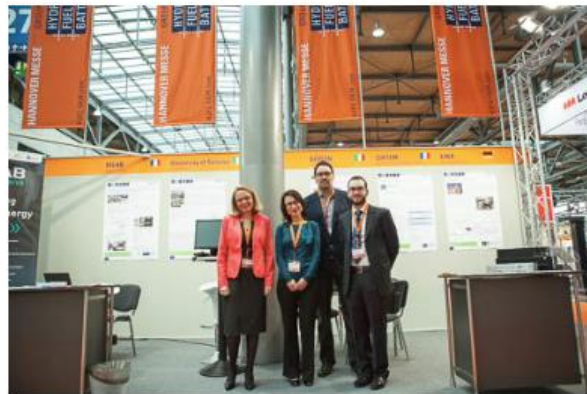
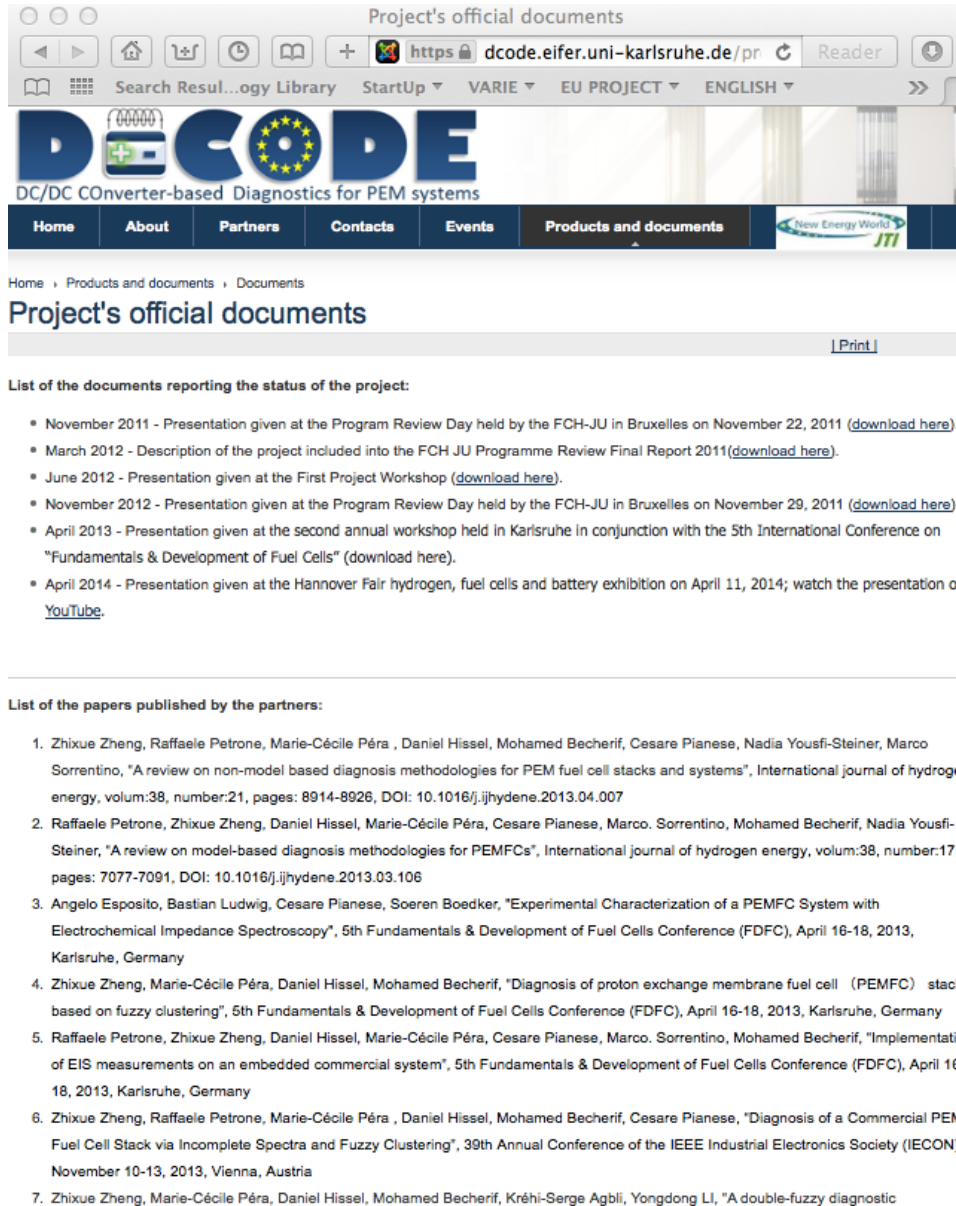

Figure 1.6.2 – Snapshot of the upper part of the website event section.

Upon decision of the Steering Committee held on March 28, 2014 the website will be active for two years after the end of the project. This is one of the main follow up actions that may help valorising the project outcomes.



The screenshot shows a web browser window displaying the 'Project's official documents' page. The browser address bar shows the URL 'https://dcode.eifer.uni-karlsruhe.de/pr'. The website header features the DCODE logo and navigation tabs: Home, About, Partners, Contacts, Events, and Products and documents. The main content area is titled 'Project's official documents' and includes a 'Print' link. Below this, there are two sections: 'List of the documents reporting the status of the project:' and 'List of the papers published by the partners:'. The first list contains six items with dates from November 2011 to April 2014, each with a 'download here' link. The second list contains seven numbered entries, each providing a full citation for a paper published in journals like 'International journal of hydrogen energy' or at conferences like '5th Fundamentals & Development of Fuel Cells Conference (FDFC)' and '39th Annual Conference of the IEEE Industrial Electronics Society (IECON)'.

Project's official documents

Home » Products and documents » Documents

Project's official documents

[Print](#)

List of the documents reporting the status of the project:

- November 2011 - Presentation given at the Program Review Day held by the FCH-JU in Bruxelles on November 22, 2011 ([download here](#)).
- March 2012 - Description of the project included into the FCH JU Programme Review Final Report 2011([download here](#)).
- June 2012 - Presentation given at the First Project Workshop ([download here](#)).
- November 2012 - Presentation given at the Program Review Day held by the FCH-JU in Bruxelles on November 29, 2011 ([download here](#)).
- April 2013 - Presentation given at the second annual workshop held in Karlsruhe in conjunction with the 5th International Conference on "Fundamentals & Development of Fuel Cells" (download here).
- April 2014 - Presentation given at the Hannover Fair hydrogen, fuel cells and battery exhibition on April 11, 2014; watch the presentation on [YouTube](#).

List of the papers published by the partners:

1. Zhixue Zheng, Raffaele Petrone, Marie-Cécile Péra , Daniel Hissel, Mohamed Becherif, Cesare Pianese, Nadia Yousfi-Steiner, Marco Sorrentino, "A review on non-model based diagnosis methodologies for PEM fuel cell stacks and systems", *International journal of hydrogen energy*, volum:38, number:21, pages: 8914-8926, DOI: 10.1016/j.ijhydene.2013.04.007
2. Raffaele Petrone, Zhixue Zheng, Daniel Hissel, Marie-Cécile Péra, Cesare Pianese, Marco Sorrentino, Mohamed Becherif, Nadia Yousfi-Steiner, "A review on model-based diagnosis methodologies for PEMFCs", *International journal of hydrogen energy*, volum:38, number:17, pages: 7077-7091, DOI: 10.1016/j.ijhydene.2013.03.106
3. Angelo Esposito, Bastian Ludwig, Cesare Pianese, Soeren Boedker, "Experimental Characterization of a PEMFC System with Electrochemical Impedance Spectroscopy", 5th Fundamentals & Development of Fuel Cells Conference (FDFC), April 16-18, 2013, Karlsruhe, Germany
4. Zhixue Zheng, Marie-Cécile Péra, Daniel Hissel, Mohamed Becherif, "Diagnosis of proton exchange membrane fuel cell (PEMFC) stack based on fuzzy clustering", 5th Fundamentals & Development of Fuel Cells Conference (FDFC), April 16-18, 2013, Karlsruhe, Germany
5. Raffaele Petrone, Zhixue Zheng, Daniel Hissel, Marie-Cécile Péra, Cesare Pianese, Marco Sorrentino, Mohamed Becherif, "Implementation of EIS measurements on an embedded commercial system", 5th Fundamentals & Development of Fuel Cells Conference (FDFC), April 16-18, 2013, Karlsruhe, Germany
6. Zhixue Zheng, Raffaele Petrone, Marie-Cécile Péra , Daniel Hissel, Mohamed Becherif, Cesare Pianese, "Diagnosis of a Commercial PEM Fuel Cell Stack via Incomplete Spectra and Fuzzy Clustering", 39th Annual Conference of the IEEE Industrial Electronics Society (IECON) November 10-13, 2013, Vienna, Austria
7. Zhixue Zheng, Marie-Cécile Péra, Daniel Hissel, Mohamed Becherif, Kréhi-Serge Agbli, Yongdong LI, "A double-fuzzy diagnostic

Figure 1.6.3 – Snapshot of the website document section.

2. Use and dissemination of foreground

Section A

2.1.1. List of all scientific (peer reviewed) publications related to the foreground of the project

TEMPLATE A1: LIST OF SCIENTIFIC (PEER REVIEWED) PUBLICATIONS, STARTING WITH THE MOST IMPORTANT ONES

NO.	Title	Main author	Title of the periodical or the series	Number, date or frequency	Publisher	Place of publication	Year of publication	Relevant pages	Permanent identifiers (if available)	Is/Will open Access provided to this publication?
1	A review on non-model based diagnosis methodologies for PEM fuel cell stacks and systems	Zhixue Zheng	International journal of hydrogen energy	Vol.: 38, number: 21, 17 July 2013	Hydrogen Energy Publications, LLC. Published by Elsevier Ltd.		2013	pp 8605-9056	DOI: 10.1016/j.ijhydene.2013.04.007	no
2	A review on model-based diagnosis methodologies for PEMFCs	Raffaele Petrone	International journal of hydrogen energy	Vol.: 38, Number: 17, 10 June 2013	Hydrogen Energy Publications, LLC. Published by Elsevier Ltd.		2013	pp 7077-7091	DOI: 10.1016/j.ijhydene.2013.03.106	no
3	Diagnosis of a Commercial PEM Fuel Cell Stack via Incomplete Spectra and Fuzzy Clustering	Zhixue Zheng	39th Annual Conference of the IEEE Industrial Electronics Society (IECON)		IEEE	Vienna (A)	November 10-13, 2013		10.1109/IECON.2013.6699371	no
4	A double-fuzzy diagnostic methodology dedicated to on-line fault diagnosis of PEMFC stack	Zhixue Zheng	Journal of power sources	In press			2014			no

5	Experimental Characterization of a PEMFC System with Electrochemical Impedance Spectroscopy	Angelo Esposito	5th Fundamentals & Development of Fuel Cells Conference (FDfC)			Karlsruhe (D)	16-18 April 2013			no
6	Diagnosis of proton exchange membrane fuel cell (PEMFC) stack based on fuzzy clustering	Zhixue Zheng	5th Fundamentals & Development of Fuel Cells Conference (FDfC)			Karlsruhe (D)	16-18 April 2013			no
7	Implementation of EIS measurements on an embedded commercial system	Raffaele Petrone	5th Fundamentals & Development of Fuel Cells Conference (FDfC)			Karlsruhe (D)	16-18 April 2013			no

2.1.2. List of all dissemination activities

No	Type of activities	Main leader	Title	Date/Period	Place	Type of audience	Countries addressed
1	International Workshop	UFC	D-CODE and GENIUS annual workshop	13-14 June 2012	Belfort (F)	International	USA, Germany, Canada, Denmark, Croatia, Italy, France
2	International Workshop	UFC	D-CODE and DIAPASON2 workshop	15-16 April 2013	Karlsruhe (D)	International	All
3	Hannover Fair Hydrogen, Fuel Cell and Battery Exhibition	UFC	Presentation of the D-CODE results	07-11 April 2014	Hannover (D)	International	20 countries worldwide
4	WEB	EIFER	D-CODE website	March 2011 December 2016	n.a.	International	All
5	Flyers	UFC	First Project Workshop	June 2012	Belfort (D)	European	All
6	Flyers	UFC	Second Project Workshop	April 2013	Karlsruhe (D)	International	All
7	Posters	ALL	Hannover Fair 5 Posters with project description	April 2014	Hannover (D)	International	All
8	Presentation Video YouTube	UNISA	Hannover fair	April 2014	Hannover (D)	International	All
9	Presentation	UNISA	FCH-JU review day	22 November 2011	Bruxelles (B)	European	EU
10	Presentation	UNISA	FCH-JU review day	29 November 2012	Bruxelles (B)	European	EU
11	Poster	UNISA	FCH-JU review day	November 2013	Bruxelles (B)	European	EU

Section B (Confidential⁸)

Part B1

TEMPLATE B1: LIST OF APPLICATIONS FOR PATENTS, TRADEMARKS, REGISTERED DESIGNS, ETC.					
Type of IP Rights ⁹ :	Confidential Click on YES/NO	Foreseen embargo date dd/mm/yyyy	Application reference(s) (e.g. EP123456)	Subject or title of application	Applicant (s) (as on the application)
Patent	YES	31/12/2014	Under submission	Identification of fuel cell impedance for on-board diagnosis applications	University of Salerno - Inventors: R. Petrone, C. Pianese, P. Polverino, M. Sorrentino

⁸ Note to be confused with the "EU CONFIDENTIAL" classification for some security research projects.

⁹ A drop down list allows choosing the type of IP rights: Patents, Trademarks, Registered designs, Utility models, Others.

Part B2

Type of Exploitable Foreground ¹⁰	Description of exploitable foreground	Confidential Click on YES/NO	Foreseen embargo date dd/mm/yyyy	Exploitable product(s) or measure(s)	Sector(s) of application ¹¹	Timetable, commercial or any other use	Patents or other IPR exploitation (licences)	Owner & Other Beneficiary(s) involved
Commercial exploitation of R&D results	Diagnostic tool for PEMFC	YES	-	Converter, EIS Board, Algorithms	D35.1.1	2016	A patent is being filed for one algorithm.	Owners of foreground to be exploited
Commercial exploitation of R&D results	Impedance analysis for electroch. devices	YES	-	EIS Board, Algorithms	D35.1.1	2016	A patent is being filed for one algorithm.	Owners of foreground to be exploited
Commercial exploitation of R&D results	Power electronics	YES	-	DC/DC converter	D35.1.1	2015	-	Owners of foreground to be exploited
Commercial exploitation of R&D results	EIS for Laboratory application	YES	-	Converter, EIS Board, Algorithms	D35.1.1	2015	A patent is being filed for one algorithm.	Owners of foreground to be exploited

The description of the foreground exploitable is available in the section 1.4.3

¹⁹ A drop down list allows choosing the type of foreground: General advancement of knowledge, Commercial exploitation of R&D results, Exploitation of R&D results via standards, exploitation of results through EU policies, exploitation of results through (social) innovation.

¹¹ A drop down list allows choosing the type sector (NACE nomenclature): http://ec.europa.eu/competition/mergers/cases/index/nace_all.html

3. Report on societal implications

A General Information		
JU Grant Agreement Number:	256673	
Title of Project:	D-CODE	
Name and Title of Coordinator:	Cesare PIANESE – Full Professor	
B Ethics		
1. Did you have ethicists or others with specific experience of ethical issues involved in the project?	<input type="radio"/>	Yes
	<input checked="" type="radio"/>	No
2. Please indicate whether your project involved any of the following issues (tick box) :		
INFORMED CONSENT		
• Did the project involve children?	NO	
• Did the project involve patients or persons not able to give consent?	NO	
• Did the project involve adult healthy volunteers?	NO	
• Did the project involve Human Genetic Material?	NO	
• Did the project involve Human biological samples?	NO	
• Did the project involve Human data collection?	NO	
RESEARCH ON HUMAN EMBRYO/FOETUS		
• Did the project involve Human Embryos?	NO	
• Did the project involve Human Foetal Tissue / Cells?	NO	
• Did the project involve Human Embryonic Stem Cells?	NO	
PRIVACY		
• Did the project involve processing of genetic information or personal data (e.g. health, sexual lifestyle, ethnicity, political opinion, religious or philosophical conviction)	NO	
• Did the project involve tracking the location or observation of people?	NO	
RESEARCH ON ANIMALS		
• Did the project involve research on animals?	NO	
• Were those animals transgenic small laboratory animals?	NO	
• Were those animals transgenic farm animals?	NO	
• Were those animals cloning farm animals?	NO	
• Were those animals non-human primates?	NO	
RESEARCH INVOLVING DEVELOPING COUNTRIES		
• Use of local resources (genetic, animal, plant etc)	NO	
• Benefit to local community (capacity building i.e. access to healthcare, education etc)	NO	
DUAL USE		
• Research having potential military / terrorist application	NO	

C Workforce Statistics**3 Workforce statistics for the project: Please indicate in the table below the number of people who worked on the project (on a headcount basis).**

Type of Position	Number of Women	Number of Men
Scientific Coordinator	0	1
Work package leader	1	5
Experienced researcher (i.e. PhD holders)	6	25
PhD Students	1	2
Other	3	NA

4 How many additional researchers (in companies and universities) were recruited specifically for this project?

NA

Of which, indicate the number of men:

NA

Of which, indicate the number of women:

NA

D Gender Aspects

5 Did you carry out specific Gender Equality Actions under the project?

Yes

No

6 Which of the following actions did you carry out and how effective were they?

	Not at all effective	Very effective
<input type="checkbox"/> Design and implement an equal opportunity policy	○ ○ ○ ○ ○	○ ○ ○ ○ ○
<input type="checkbox"/> Set targets to achieve a gender balance in the workforce	○ ○ ○ ○ ○	○ ○ ○ ○ ○
<input type="checkbox"/> Organise conferences and workshops on gender	○ ○ ○ ○ ○	○ ○ ○ ○ ○
<input type="checkbox"/> Actions to improve work-life balance	○ ○ ○ ○ ○	○ ○ ○ ○ ○
<input type="radio"/> Other: <input style="width: 300px;" type="text"/>		

7 Was there a gender dimension associated with the research content – i.e. wherever people were the focus of the research as, for example, consumers, users, patients or in trials, was the issue of gender considered and addressed?

Yes- please specify

No

E Synergies with Science Education

8 Did your project involve working with students and/or school pupils (e.g. open days, participation in science festivals and events, prizes/competitions or joint projects)?

Yes- please specify: Several PhD, Master and Bachelor students were involved into the project D-CODE.

No

9 Did the project generate any science education material (e.g. kits, websites, explanatory booklets, DVDs)?

Yes- please specify: Mostly, the result of the work made by PhD students is a solid basis for the preparation of educational material on EIS diagnosis for FC.

No

F Interdisciplinarity

10 Which disciplines (see list below) are involved in your project?

Main discipline¹²: 2.2; 2.3

Associated discipline:

G Engaging with Civil society and policy makers

11a Did your project engage with societal actors beyond the research community? (if 'No', go to Question 14)

Yes

No

11b If yes, did you engage with citizens (citizens' panels / juries) or organised civil society (NGOs, patients' groups etc.)?

No

Yes- in determining what research should be performed

Yes - in implementing the research

Yes, in communicating /disseminating / using the results of the project

¹² Insert number from list below (Frascati Manual)

11c In doing so, did your project involve actors whose role is mainly to organise the dialogue with citizens and organised civil society (e.g. professional mediator; communication company, science museums)?	<input type="radio"/> <input type="radio"/>	Yes No
12 Did you engage with government / public bodies or policy makers (including international organisations)		
<input type="radio"/> No <input type="radio"/> Yes- in framing the research agenda <input type="radio"/> Yes - in implementing the research agenda <input type="radio"/> Yes, in communicating /disseminating / using the results of the project		
13a Will the project generate outputs (expertise or scientific advice) which could be used by policy makers? <input type="radio"/> Yes – as a primary objective (please indicate areas below- multiple answers possible) <input type="radio"/> Yes – as a secondary objective (please indicate areas below - multiple answer possible) <input type="radio"/> No		
13b If Yes, in which fields? (see text in bold below)		
Agriculture Audiovisual and Media Budget Competition Consumers Culture Customs Development Economic and Monetary Affairs Education, Training, Youth Employment and Social Affairs	Energy Enlargement Enterprise Environment External Relations External Trade Fisheries and Maritime Affairs Food Safety Foreign and Security Policy Fraud Humanitarian aid	Human rights Information Society Institutional affairs Internal Market Justice, freedom and security Public Health Regional Policy Research and Innovation Space Taxation Transport
13c If Yes, at which level? <input type="radio"/> Local / regional levels <input type="radio"/> National level <input type="radio"/> European level <input type="radio"/> International level		

H Use and dissemination			
14	How many Articles were published/accepted for publication in peer-reviewed journals?	7	
	To how many of these is open access ¹³ provided?	0	
	How many of these are published in open access journals?	0	
	How many of these are published in open repositories?	0	
	To how many of these is open access not provided?	4	
	Please check all applicable reasons for not providing open access:		
	<input checked="" type="checkbox"/> publisher's licensing agreement would not permit publishing in a repository <input type="checkbox"/> no suitable repository available <input type="checkbox"/> no suitable open access journal available <input type="checkbox"/> no funds available to publish in an open access journal <input type="checkbox"/> lack of time and resources <input type="checkbox"/> lack of information on open access <input type="checkbox"/> other:		
15	How many new patent applications ('priority filings') have been made? (A patent is being filed).	1	
16	Indicate how many of the following Intellectual Property Rights were applied for (give number in each box).	Trademark	0
		Registered design	0
		Other	0
17	How many spin-off companies were created / are planned as a direct result of the project?	0	
	<i>Indicate the approximate number of additional jobs in these companies:</i>		
18	Please indicate whether your project has a potential impact on employment, in comparison with the situation before your project:		
	<input type="checkbox"/> Increase in employment, or <input type="checkbox"/> Safeguard employment, or <input type="checkbox"/> Decrease in employment, <input checked="" type="checkbox"/> Difficult to estimate / not possible to quantify	<input type="checkbox"/> In small & medium-sized enterprises <input type="checkbox"/> In large companies <input type="checkbox"/> None of the above / not relevant to the project <input type="checkbox"/>	
19	For each project partner, please estimate the employment effect resulting directly from your participation in Full Time Equivalent (FTE = one person working fulltime for a year) jobs: Difficult to estimate	Indicate figure:	

¹³ Open Access is defined as free of charge access for anyone via the internet.

I Media and Communication to the general public

20 As part of the project, were any of the beneficiaries professionals in communication or media relations?

- Yes No

21 As part of the project, have any beneficiaries received professional media / communication training / advice to improve communication with the general public?

- Yes No

22 Which of the following have been used to communicate information about your project to the general public, or have resulted from your project?

- | | |
|--|---|
| <input type="checkbox"/> Press Release | <input type="checkbox"/> Coverage in specialist press |
| <input type="checkbox"/> Media briefing | <input type="checkbox"/> Coverage in general (non-specialist) press |
| <input type="checkbox"/> TV coverage / report | <input type="checkbox"/> Coverage in national press |
| <input type="checkbox"/> Radio coverage / report | <input type="checkbox"/> Coverage in international press |
| <input checked="" type="checkbox"/> Brochures / posters / flyers | <input checked="" type="checkbox"/> Website for the general public / internet |
| <input type="checkbox"/> DVD / Film / Multimedia | <input checked="" type="checkbox"/> Event targeting general public (festival, conference, exhibition, science café) |

23 In which languages are the information products for the general public produced?

- | | |
|--|---|
| <input type="checkbox"/> Language of the coordinator | <input checked="" type="checkbox"/> English |
| <input type="checkbox"/> Other language(s) | |