

# DESTA Periodical Report

---

## D6.3



[www.desta-project.eu](http://www.desta-project.eu)

<b>Confidentiality</b>	CO	<b>Deliverable Type</b>	R
<b>Project</b>	DESTA	<b>Project Number</b>	278899
<b>Contact Person</b>	Jürgen Rechberger	<b>Organization</b>	AVL
<b>Phone</b>	+43 316 787 3426	<b>E-mail</b>	Juergen.rechberger.avl.com

The research leading to these results has received funding from the European Union's Seventh Framework Programme (FP7/2007-2013) for the Fuel Cells and Hydrogen Joint Technology Initiative under grant agreement n° 278899

## Table of Contents

1	Introduction, .....	5
2	Publishable Summary.....	5
3	Project objectives for the period .....	8
4	WP3 – Stack Optimization – Work progress and achievements during the period.....	8
4.1	Objectives .....	8
4.2	Overall progress in the first period of the project.....	8
4.3	Task 3.1 - Delivery of stacks for system evaluation.....	8
4.4	Task 3.2 - Durability and Lifetime optimization.....	9
4.4.1	Overview of lifetime tests .....	9
4.4.2	Thermal cycling test with power operation .....	11
4.5	Task 3.3 - Diesel operation .....	12
4.5.1	Improved analysis tool.....	14
4.5.2	Test results with anode modifications.....	15
4.5.3	Recommendations for the stack operation strategy .....	17
4.6	Task 3.4, Delivery and integration of next generation stacks for truck APU.....	18
4.6.1	Improvement of gaskets, September 2012 .....	18
4.6.2	Change of interconnect design .....	19
4.6.3	Final stack design .....	20
4.7	Results and achievements .....	24
4.8	Deviations and corrective actions .....	24
4.9	Conclusions.....	25
4.10	Interactions between WP's .....	26
4.11	Use of Person Months .....	<b>Fejl! Bogmærke er ikke defineret.</b>

## List of Figures

FIGURE : EBERSPÄCHER PROTOTYPE (c) CCES .....	5
FIGURE : AVL PROTOTYPE (c) AVL .....	5
FIGURE : DESTA VALUE CHAIN (c) DESTA.....	6
FIGURE : THE STACK MODULE AND THE BOXER CONFIGURATION USED IN THIS APPLICATION, SHOWING THE ELECTRIC TERMINALS AND THE AIR AND FUEL INLETS/OUTLETS.....	9

FIGURE 2: CELL GROUP VOLTAGES MEASURED EACH TIME STACK “O” REACHES IT’S REFERENCE CONDITIONS DURING A 90 THERMAL CYCLE TEST. FOR EACH THERMAL CYCLE, THE STACK WAS TAKEN THROUGH FEW OPERATING POINTS. AFTER ELIMINATION OF ONE OF THEM, THE CYCLE TIME WAS 3 HOURS, AND THE TEMPERATURE CYCLED BETWEEN OPERATION AND COLD (100°C). .....11

FIGURE 1: TREND OF (A) CELL POTENTIAL AND (B) EXIT GAS COMPOSITION UPON INCREASING THE CONCENTRATION OF H<sub>2</sub>S SHOWING THE EFFECT OF INHIBITING THE WATER GAS SHIFT REACTION. ....13

FIGURE 3: EQUIPMENT AND ITS GENERAL CHARACTERISTICS. ....15

FIGURE 4: IMPROVEMENTS IN CELL POTENTIAL FOR VARIOUS GENERATION OF CELLS, ALL OPERATING AT 270 MA/CM<sup>2</sup> AND 60% FU .....16

FIGURE 5: LONG TERM TESTS OF STACKS ON DIESEL REFORMATE WITH SULFUR. SOME OF THESE TESTS HAVE BEEN FUNDED BY THE SCOTAS PROJECT. ....17

FIGURE 6: DROP IN CELL POTENTIAL OVER TIME FOR TWO STACKS(GEN 4) IN SIMULATED ULSD REFORMATE FEED WITH SULPHUR.....18

FIGURE 6: THE STACK MODULE AND THE BOXER CONFIGURATION USED IN THIS APPLICATION, SHOWING THE ELECTRIC TERMINALS AND THE AIR AND FUEL INLETS/OUTLETS..... **FEJL! BOGMÆRKE ER IKKE DEFINERET.**

FIGURE 7: THE STACK IN A MODULE AND THE GASKET BETWEEN THE STACK CORE AND THE INTERFACE PLATE.....19

FIGURE 8: THE INTRODUCTION OF THE TSP STACK GEOMETRY IN FEBRUARY 2013. ....20

FIGURE 9: THE LAYOUT OF FUEL INLETS AND OUTLETS IN THE TSP1 STACK. THE CORRESPONDING BOXER MANIFOLD DESIGN IS ALSO SHOWN HERE. ....20

FIGURE 10: LEAKAGE SOLUTION FOR STACK IN SUMMER 2013. ....21

FIGURE 11: LEAKAGE SOLUTION FOR STACK IN SPRING 2014.....21

FIGURE 12: IMPROVEMENTS ON LEAK AFTER CHANGE IN LEAKAGE SOLUTION. ....22

FIGURE : EFFORTS WP3..... **FEJL! BOGMÆRKE ER IKKE DEFINERET.**

**List of Tables**

TABLE 1. OVERVIEW OF RELEVANT LIFETIME TESTS FOR THE DESTA PROJECT. WITHOUT SULPHUR. ....10

TABLE 2. OVERVIEW OF RELEVANT LIFETIME TESTS FOR THE DESTA PROJECT. WITH SULPHUR. ....12

TABLE : WP3 PERSON MONTH - EXPLANATION ON DEVIATION..... **FEJL! BOGMÆRKE ER IKKE DEFINERET.**

**Abbreviations**

Abbreviation	Long Version
APU	Auxiliary Power Unit
AUTOSAR	AUTomotive Open System ARchitecture
CAN	Controller Area Network
DC	Direct Current
DESTA	Demonstration of 1st European SOFC Truck APU
ECU	Electric Control Unit
EMC	Electric Magnetic Compatibility
FC-APU	Fuel Cell Auxiliary Power Unit
HW	Hardware
Ppm	Parts Per Million
SOC	State Of Charge
V	Volt

---

--	--

**Main Authors**

<b>Person</b>	<b>Organisation</b>
Jonas Hagerskans	VOLVO
Christoffer Greisen	TOFC
Ingrid Kundner	AVL
Jürgen Rechberger	AVL
Andreas Kaupert	CCES

# PROJECT PERIODIC REPORT

*Contribution by TOFC, Christoffer Greisen, October 10, 2014*

**FCH JU Grant Agreement number: 278899**

**Project acronym: DESTA**

**Project title: Demonstration of 1<sup>st</sup> European SOFC Truck APU**

**Funding Scheme: FCH-JU**

**Date of latest version of Annex I against which the assessment will be made:**

**Periodic report:**                    1<sup>st</sup>     2<sup>nd</sup>

**Period covered:**                    from                    01.01.2012 to 15.10.2014

**Name, title and organisation of the scientific representative of the project's coordinator:**

**DI Jürgen Rechberger, Manager Fuel Cell, AVL List GmbH**

**Tel: +43 316 787 3426**

**Fax:**

**E-mail: Juergen.rechberger@avl.com**

**Project website address: [www.esta-project.eu](http://www.esta-project.eu)**

## 1 Introduction,

Due to the closure of TOFC, this report is intended to serve either as an appendix to the final report, or as a final technical report from TOFC in order to secure acceptance that all obligations are fulfilled with only minor deviations. This acceptance has been given to TOFC at a Steering Committee meeting in Göteborg on October 8, 2014.

## 2 Publishable Summary

On 1st of January 2012, the research project DESTA started under the coordination of AVL List GmbH (Austria). It is the goal of DESTA to demonstrate the first European Solid Oxide Fuel Cell (SOFC) Auxiliary Power Unit (APU) on board of a heavy duty truck.

By gathering the project partners Eberspächer Climate Control Systems GmbH & Co. KG

(Germany), AVL List GmbH (Austria), Volvo (Sweden), Topsoe Fuel Cell (Denmark) and Forschungszentrum Jülich (Germany) into one consortium, a 100% European value chain for a SOFC APU is established. With the aim to reduce emissions, noise and costs, the end product will have excellent export opportunities, creating new high- & clean teach job opportunities in Europe.



A significant advantage of the SOFC technology in contrast to other fuel cell technologies is its compatibility with conventional road fuels like diesel. The DESTA partners Eberspächer and AVL put a lot of effort in bringing the SOFC APU technology to a prototype level (see Figure 1 and Figure 2). For a market entry of this technology, the final breakthrough milestone is the demonstration of its functionality on a truck; the major goal of the DESTA project.

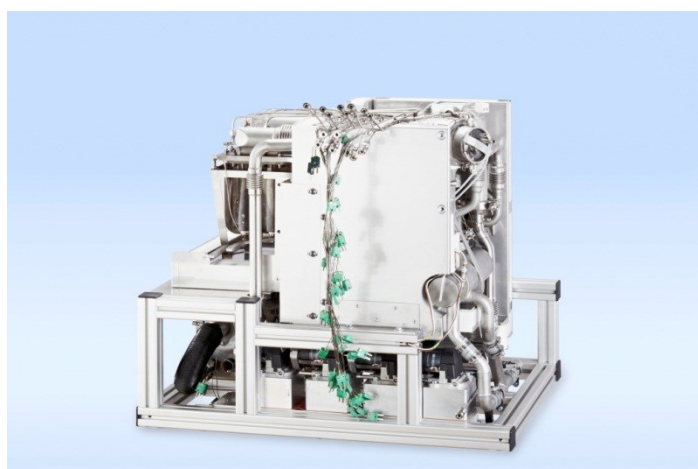

Figure 1: Eberspächer prototype (c) CCES



Figure 2: AVL prototype (c) AVL

The first phase of the project defines the requirements for the application of a SOFC APU in a Volvo heavy-duty truck for the US market. Based on test results including production costs, controllability and manufacturability of the existing systems from AVL and Eberspächer, a benchmark will be performed by

the independent research institute Forschungszentrum Jülich. During the course of the project, Topsoe Fuel Cell has worked on the SOFC stack optimization and deliveries of stacks to both integrator partners as needed. By time of writing, the consortium is confident that the stacks delivered by TOFC are sufficiently mature and available in sufficient amount to perform a truck demonstration in late 2014 or early 2015.

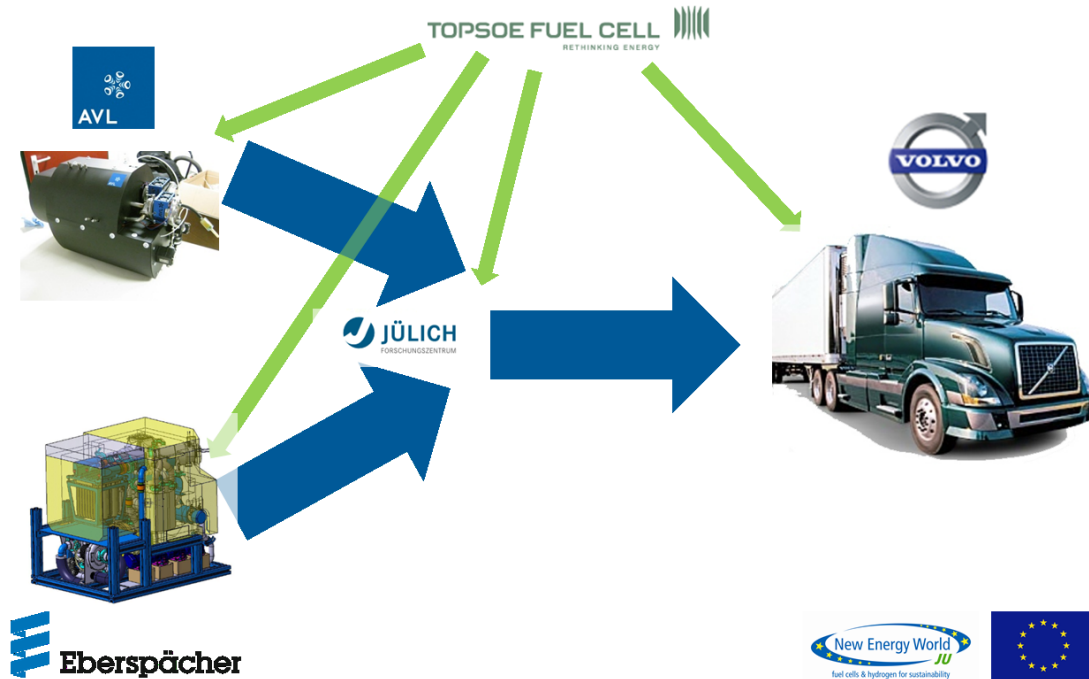

Figure 3: DESTA value chain (c) DESTA

## Objectives

The main objective of DESTA is the demonstration of the first European Solid Oxide Fuel Cell (SOFC) Auxiliary Power Unit (APU) for trucks:

- Maximum electrical power  $\geq 3\text{kW}$
- Operation on conventional road diesel fuel
- Long-term tests:  $\sim 300$  thermal cycles and  $\sim 3.000$  operating hours
- System electrical net efficiency around 35%
- System volume and weight below 150 l and 120 kg
- CO<sub>2</sub> reduction of 75% compared to engine idling of a heavy-duty truck
- Start-up time of  $\sim 30\text{min}$
- Noise level  $\sim 65\text{dB(A)}$
- Truck integration

## Achievements to date

---

In late 2012 and early 2013, TOFC reached significant improvements of the stacks towards sulfur tolerance, operation on fuel compositions similar to what is seen in an APU system and thermal cycles.



### 3 Project objectives for the period

All stack deliveries have been completed

All technical deliverable reports have been submitted.

## 4 WP3 – Stack Optimization – Work progress and achievements during the period

### 4.1 Objectives

The objectives of this work package are to design, manufacture/produce, test, ship, and integrate SOFC stacks optimized for diesel applications and the fully integrated mobile APU system and its durability and performance objectives.

### 4.2 Overall progress in the first period of the project

In the first half of the project the activities centered on delivering stacks to the two integrator partners, AVL and Eberspächer. The stack need changed, as it turned out that it would not be possible to meet the requirements developed in WP1 with a single stack system. Hence, a manifold for a boxer configuration of two stacks was developed and the number of stacks to be supplied was adjusted.

On the testing side, analysis early in the project showed that the weakest point in the stack module construction was actually the gaskets inside the stack module. A rapid thermal cycling test in which EAP is used for stack protection has been used to screen solutions to these gasket issues. The current status is that the gasket isolating the stack core from the stack module is robust and fulfills its requirements.

A change of interconnect was implemented in March 2013. The new interconnect had been developed for TOFC's stationary applications in other projects and had shown good results.

### 4.3 Task 3.1 - Delivery of stacks for system evaluation

The aim of this task was to supply stacks for the system evaluation. During the project it turned out that the systems would not reach 3 kW on a single stack, provided the gas composition to be expected. Hence it was acknowledged that more stacks were needed. A total of 16 stacks were delivered in this phase.

TOFC stacks are based on planar anode supported cells with metallic interconnects. The stack design used for APU applications has a side air manifold and internal fuel manifold and is integrated into a stack module.



Figure 4: The stack module and the boxer configuration used in this application, showing the electric terminals and the air and fuel inlets/outlets.

This includes a cast casing containing:

- (1) A high temperature compression system, that holds the stack itself in place, ensures mechanical integrity and secures tightness of the gaskets inside the module.
- (2) A flat interface allowing for bolting on to the system, either as a single stack, or – for the DESTA systems – in a twin/boxer configuration.
- (3) Electrical isolation of both terminals of the stack itself, so that the casing can be connected to vehicle ground and allowing for galvanic isolation of the high voltage part of the system.
- (4) Power outlet feedthroughs.
- (5) Voltage probe feedthroughs, connecting to some of the interconnects in the stack. These allow for diagnostics during development.

With the design of the stack module, the air flow to the stack also functions as a purge flow around the stack, ensuring that any leaking fuel is picked up by the air flow and fed to the burner. Hence the design with external air eliminates any safety concern related to possible leaks.

#### 4.4 Task 3.2 - Durability and Lifetime optimization

The stacks have been tested under a number of operating conditions to ensure their performance and mechanical integrity under harsh thermomechanical stresses. To this end, two gases are used: One composition resembles the real fuel expected in the APU system. The other ogas is a reforming fuel based on  $\text{CH}_4$ , which will subject the stack to thermomechanical stresses due to the cooling effect when  $\text{CH}_4$  and water is reformed inside the stack to form  $\text{CO}$  and  $\text{H}_2$ .

##### 4.4.1 Overview of lifetime tests

In table 1 all the relevant stack testing done at TOFC within the DESTA project are shown. The tests shown here are test without sulfur in the fuel, and the tests includes both QA, robustness, and lifetime (degradation) tests.

**Table 1. Overview of relevant lifetime tests for the DESTA project. Without sulphur.**

Stack (TOFC)	Stack	No. of cells	Hot test time (hours)	Load cycles in reforming fuel	Load cycles in H <sub>2</sub> based fuel	Thermal cycles	Comments
R-011	A	84	1596	-	-	8	Degradation test. Tested outside DESTA project. Current 35 A during test.
R-028	B	84	130	-	15	6	QA test.
R-033	C	84	42	-	5	2	QA test.
R-035	D	80	19	-	8	50	Led to design improvement.
R-040	E	80	145	-	10	115	Lost only 0.1 V of 63 V in 110 thermal cycles
R-042	F	84	25	-	5	2	QA test.
R-044	G	84	600	-	20	97	Thermal cycle test. Led to design improvement.
R-045	H	84	97	-	15	5	QA test.
R-050	I	84	883	-	10	61	Degradation test. Taken apart for analysis of micro defects.
Q-188	J	75	66	10	10	2	QA test. First TSP-1 stack in DESTA project.
Q-220	K	65	475	10	10	5	QA test.
Q-222	L	75	940	10	10	28	Degradation test.
Q-235	M	75	132	20	20	4	QA test.
Q-332	N	75	43	5	5	2	QA test.
Q-401	O	75	190	-	-	90	Thermal cycle test.
Q-466	P	75	600	5	5	4	Degradation test. Anode modification.
Q-467	Q	75	1219	5	5	4	Degradation test. Anode modification. Stack is still in good shape.
Q-539	R	75	2500	27	5	12	Degradation test. Anode modification. Stack is still in good shape.

To verify that the stacks are fit for the application including a weekly full cooldown and heatup, an accelerated test method has been developed so that a full thermal cycle can be completed in less than 4 hours. With this test it was shown that the stacks can withstand more than 100 thermal cycles without any damage.

#### 4.4.2 Thermal cycling test with power operation

One of the stacks with the latest modifications, stack “O”, has endured 90 rapid thermal cycles in a furnace based test, where the stack is cycled between 25 A operation on a H<sub>2</sub>/N<sub>2</sub> mixture at an operating temperature (~700°C) and cold conditions (<100 °C).

As seen in Figure 5: Cell group voltages measured each time stack “O” reaches it’s reference conditions during a 90 thermal cycle test, a stable and almost constant degradation is the dominating effect. The steps are directly correlated with the change in cathode inlet temperature. After 90 thermal cycles the spread in cell group voltage is still only 1 %, which indicates that the cycling has done little if any damage to the stack.

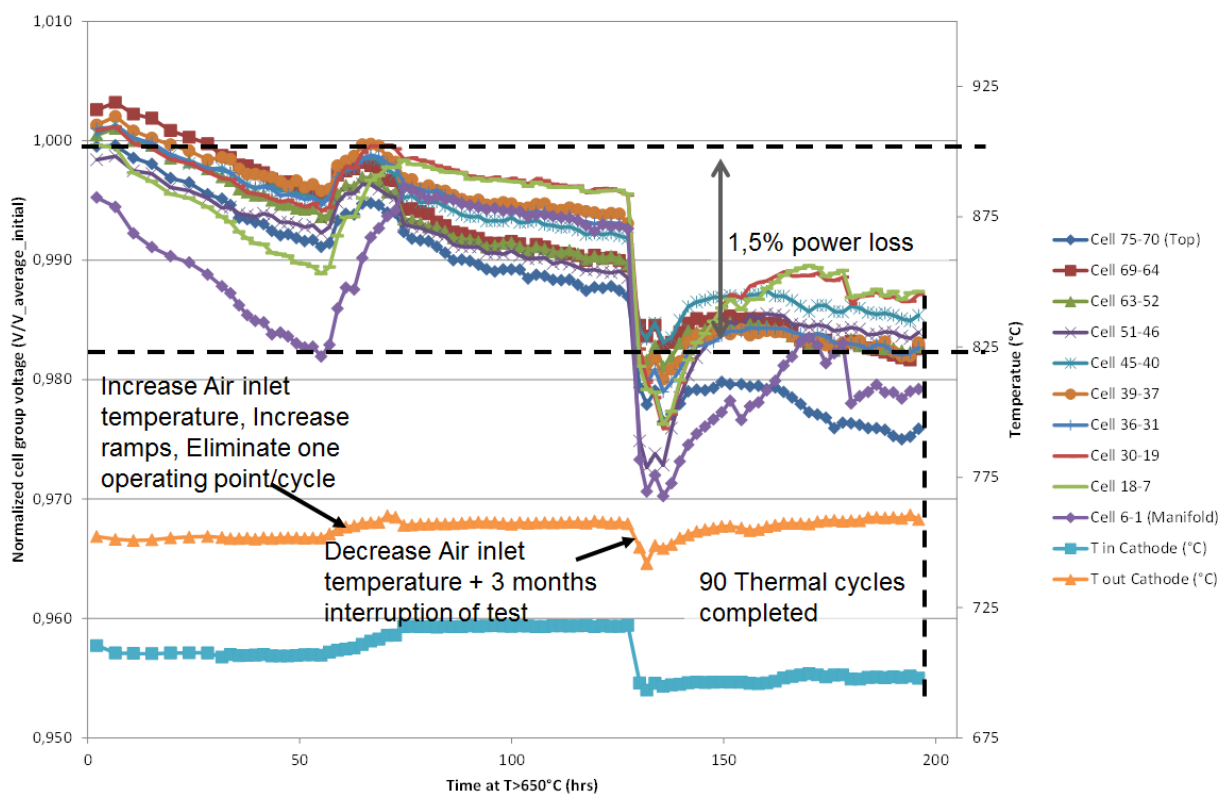

Figure 5: Cell group voltages measured each time stack “O” reaches it’s reference conditions during a 90 thermal cycle test. For each thermal cycle, the stack was taken through few operating points. After elimination of one of them, the cycle time was 3 hours, and the temperature cycled between operation and cold (100°C).

A number of representative test results obtained on full size stacks combining these test methods is summarized in Table 1.

#### 4.5 Task 3.3 - Diesel operation

**Table 2. Overview of relevant lifetime tests for the DESTA project. With sulphur.**

Stack (TOFC)	Stack	No. of cells	Hot Test time (hours)	Load cycles in H <sub>2</sub> based fuel	Thermal cycles	Comments
T-038	1	25	2200	-	-	At 2 ppm and 20 ppm S. in simulated diesel reformat.
K-452	2	25	1100	-	2	At 2 ppm and 25 ppm S. in simulated diesel reformat.
K-570	3	11	900	-	2	At 2 ppm S. in simulated diesel reformat. Regeneration.
K-654	4	11	600	-	2	At 2 ppm S. in simulated diesel reformat. Regeneration.
K-681	5	11	2462	90	4	At 0.6 ppm S. in simulated diesel reformat. Regeneration.

The most important contaminant to consider for diesel operation is sulphur, which main impact is the poisoning of the water-gas shift reaction in the stack

The tests with sulphur are further elaborated in D.3.3, Fuel tolerance test report.

To accept the sulphur levels of ULSD, the anodes have been modified. These modifications have been tested on stacks with 11-25 cells. The anode modification has been implemented and verified in some of the full size stacks used for developing the two APU systems. For this purpose, several 11 and 25 cell stacks have been tested upto 20 ppm sulfur in simulated AVL diesel reformat to study the long term performance (order of 600-2000 h), i.e., degradation of cell potentials. The stack degradation for the Generation 4 stacks shown in the figure below was reduced to 20 mV/kh by optimizing the cells.

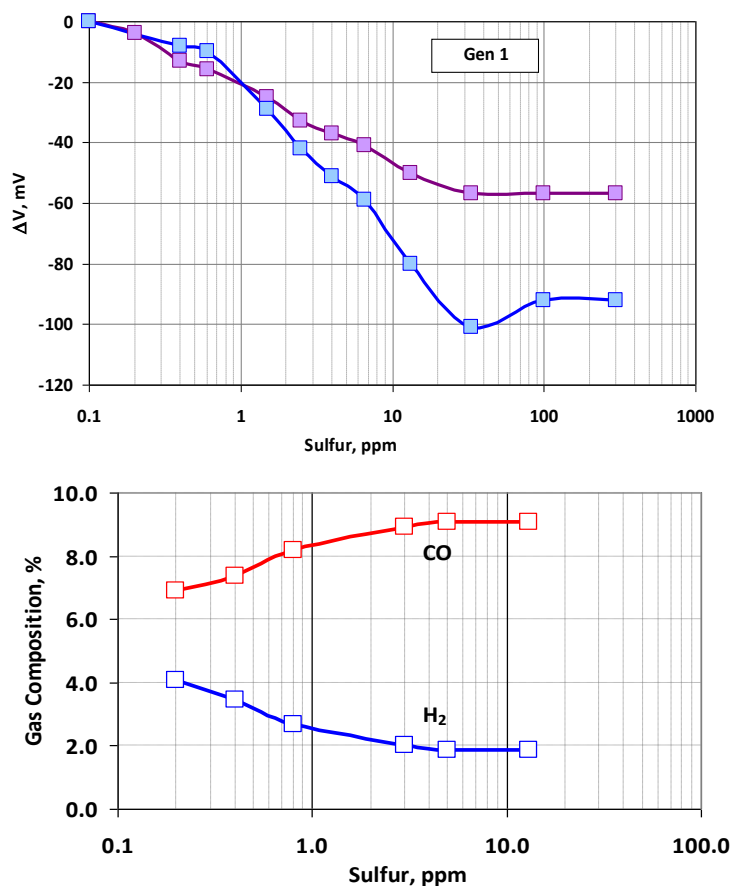

Figure 6: Trend of (top) cell potential and (bottom) exit gas composition upon increasing the concentration of H<sub>2</sub>S showing the effect of inhibiting the water gas shift reaction.

At the start of the project, using Sc-YSZ in the anode was considered a promising path. However, due to the scarcity and cost limitations of Sc, it was decided to follow other paths towards sulphur tolerance. A background IP search was conducted with the assistance of TOFC's mother company Haldor Topsoe A/S (HTAS) to find ways to improve the sulfur tolerance of the stacks. The availability of secret know-how of materials and their processing methods at HTAS allowed us to use the relevant IPs for the development of sulfur tolerant cells.

A series of materials were screened and characterized for water gas shift activity with and without sulfur and the most active material was chosen as anode material. In the first step, the water gas shift activity was studied over powdered Ni anode for various composition of CO, H<sub>2</sub>O, CO<sub>2</sub>, H<sub>2</sub> and N<sub>2</sub> in the gas feed. A rate expression for water gas shift reaction was developed and impact of sulfur was studied over this

rate. It was found that sulfur deactivates the water gas shift reaction instantaneously. Four potential materials were further investigated for water gas shift activity and the impact of sulfur was studied on these materials and the one with the best activity for water gas shift reaction in the presence of sulfur was chosen to modify our anode. The selection of the materials and initial evaluation was supported by EUDP<sup>1</sup>. However, the long term effects of the best material were investigated under SCOTAS<sup>2</sup> and DESTA projects.

Anode Material	Conversion of CO	Sulfur Composition
Ni	High (Equilibrium conversion achieved)	0
Ni	Negligible (<1%) at BOL and deactivated over time	0.3 ppm
Ni-M1	Deactivated over time	0 ppm
Ni-M2	Deactivated over time (Necessary phase was probably not obtained)	0 ppm
Ni-M3	Good shift activity	0.3 ppm
Ni-M4	Good shift activity (More than M3)	0.3 ppm

#### 4.5.1 Improved analysis tool

It was of considerable interest to understand the mechanism of interaction of H<sub>2</sub>S with Ni anode, more specifically, the composition of sulfur species in the exit gas and the concentration dependence with current densities, fuel utilization, concentration of H<sub>2</sub>S in the feed etc. This understanding is important to improve the sulfur tolerance of the cell. A search was conducted in the market for the appropriate equipment and large amount of time was spent on shipping of equipment from USA, set-up, safety protocols, calibration, troubleshooting of the equipment for a proper operation. The tool was

<sup>1</sup>, "Fuel Cells Put to Work", supported by Danish Funding, EUDP, j.nr. 64010-0052

<sup>2</sup> SCOTAS: "Sulphur, carbon, and re-oxidation tolerant anodes and anode supports for solid oxide fuel cells", FCH-JU, GA 256730

operational around April 2013, and from this time the development on sulphur tolerance could be accelerated. A picture and specification of such equipment is shown below.

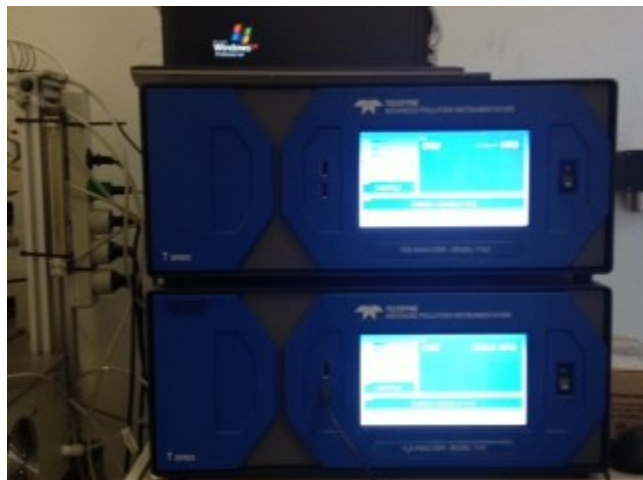

**General**

Ranges:	<p>H<sub>2</sub>S                      Min: 0-50 ppb Full scale                      Max: 0-10 ppm Full scale</p> <p>SO<sub>2</sub>                      Up to 0-20 ppm Full scale                      (selectable, independent ranges and auto ranging supported)</p>
Measurement Units:	ppb, ppm, µg/m <sup>3</sup> , mg/m <sup>3</sup> (selectable)
Zero Noise:	< 0.2 ppb (RMS)
Span Noise:	< 0.5% of reading (RMS) above 50 ppb
Lower Detectable Limit:	0.4 ppb
Zero Drift:	< 0.5 ppb/24 hours
Span Drift:	< 0.5% of full scale/24 hours
Lag Time:	20 seconds
Rise and Fall Time:	< 120 seconds to 95%
Linearity:	1% of full scale
Precision:	0.5% of reading above 50 ppb
Sample Flow Rate:	650 cm <sup>3</sup> /min ±10%

Figure 7: Equipment and its general characteristics.

**4.5.2 Test results with anode modifications**

Figure 4 shows the improvements in cell potential for the cells run under simulated diesel reformat with 0-20 ppm H<sub>2</sub>S. An improvement of about 160 mV per cell is observed (comparing Gen 4 with Gen



1) for the conditions relevant to an APU based systems. These improvements are the result of adding sulfur tolerant shift promoters into the anode microstructure. The modifications have been tested on stacks with 11-25 cells. The anode modification has been implemented and verified in some of the full size stacks used for developing the two APU systems. Most of the improvements in the cell potential is the result of a higher water gas shift activity in the presence of sulfur.

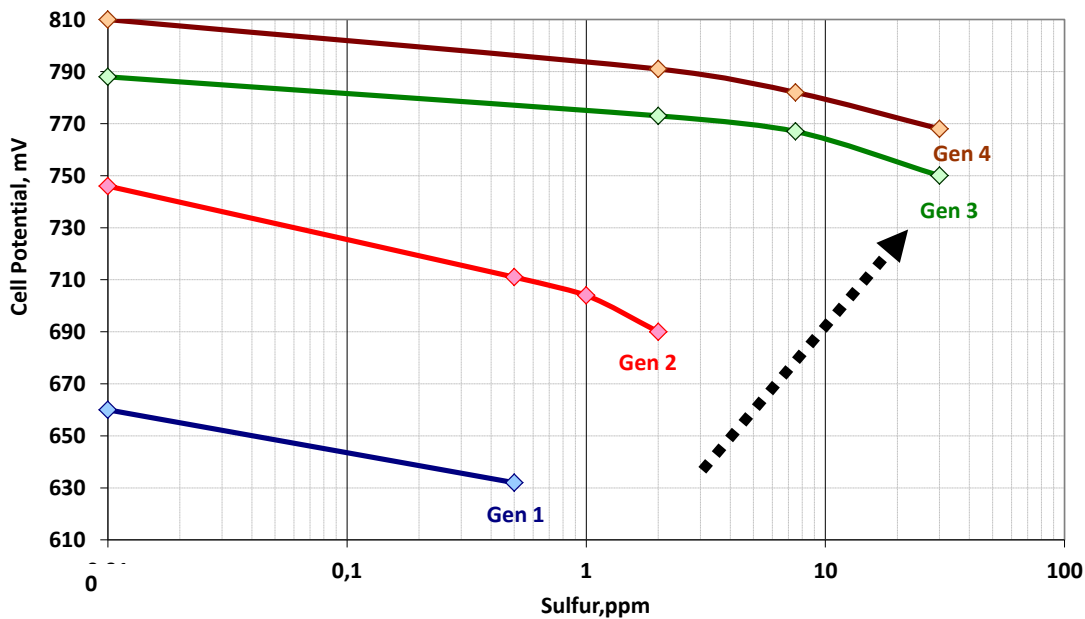

Figure 8: Improvements in cell potential for various generation of cells, all operating at  $270 \text{ mA/cm}^2$  and 60% FU

The current long term results show that without changes to the operating strategy of the stack, the degradation rate is too fast to meet the lifetime requirements, even with the improved Gen 4 cell formulation. The stacks were tested for long term with a gas composition<sup>3</sup> given by AVL and higher sulfur concentration (2 and 20 ppm  $\text{H}_2\text{S}$ ) than required by DESTA conditions. The results are shown in the graph below in figure 5. The experiments were run at different conditions of fuel utilization and current densities to see the effect on degradation and tolerance of the anode towards the sulfur.

<sup>3</sup> For detailed composition, please consult *D.1.3 APU Stack test standards*.

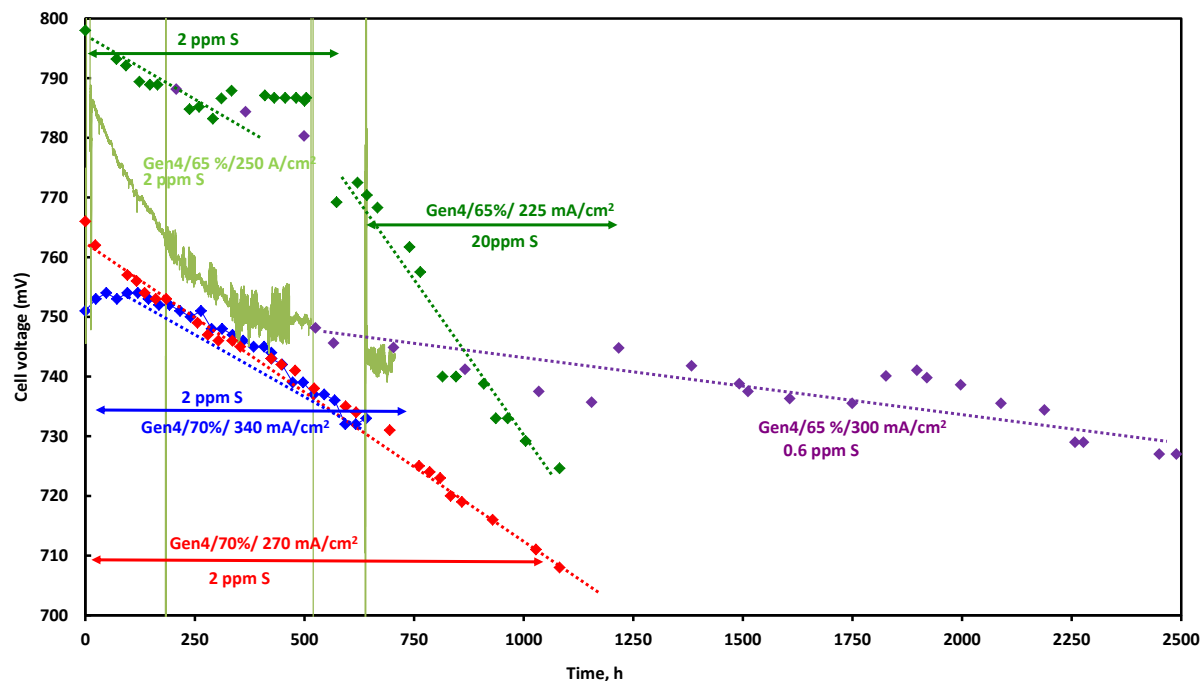

Figure 9: Long term tests of stacks on diesel reformat with sulfur. Some of these tests have been funded by the SCOTAS project.

### 4.5.3 Recommendations for the stack operation strategy

It is recommended to use a regeneration approach, in which during the daily driving, the system regenerates the stacks. This regeneration approach was identified through our corporate R&D group. Operating with such a regeneration approach will lower the degradation rate significantly, as shown in Figure 6, where it is observed that after application of regeneration strategy for our cells (Gen 4), the degradation rate of stacks has decreased significantly under simulated ULSD reformat conditions.

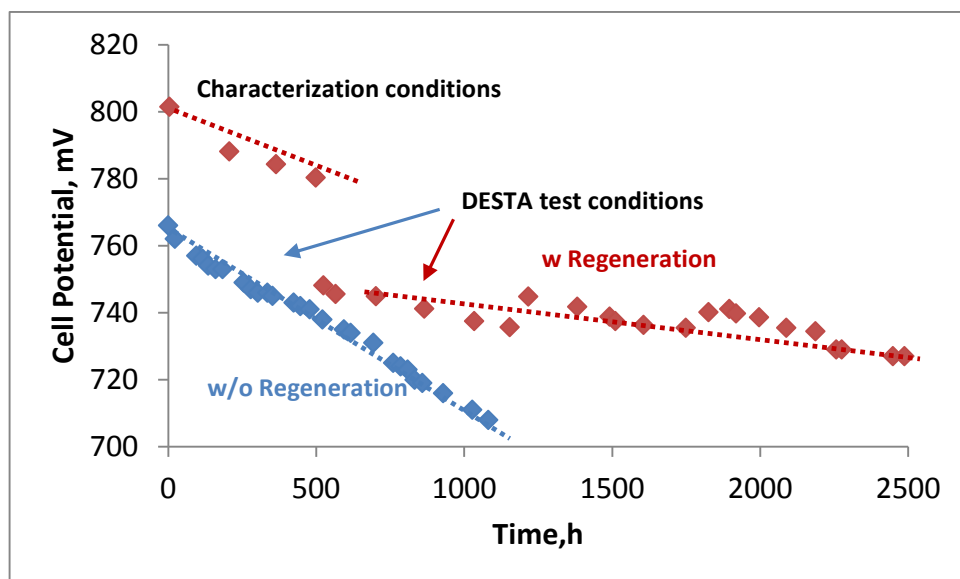

Figure 10: Drop in cell potential over time for two stacks(Gen 4) in simulated ULSD reformat feed with sulphur.

One regeneration cycle constitutes a 18 h on full load operation and 4 hours of regeneration on regen gas at 0 A and 2 hours for the load cycle (0-26-0 A). The regen gas allows the sulfur adsorbed on the anode to be released in the form of  $H_2S$ . The amount of sulfur released from the anode depends on the flow rate of the regen gas, time of regeneration and type of regen gas. A number of tests have been carried out screening gas compositions that would be possible to obtain the the DESTA demonstrator system. At they time of writing they have – however – not been successful.

#### 4.6 Task 3.4, Delivery and integration of next generation stacks for truck APU

After the initial stack deliveries, a number of improvements were made. In the following these will be elaborated with reference to the stack numbers and tests.

##### 4.6.1 Improvement of gaskets, September 2012

In September 2012, cycling tests (see **Fejl! Henvisningskilde ikke fundet.** with stack “G”) showed that the weak spot was in the gaskets, which was torn apart due to alternating thermal stresses. The gasket is shown in Figure 11.

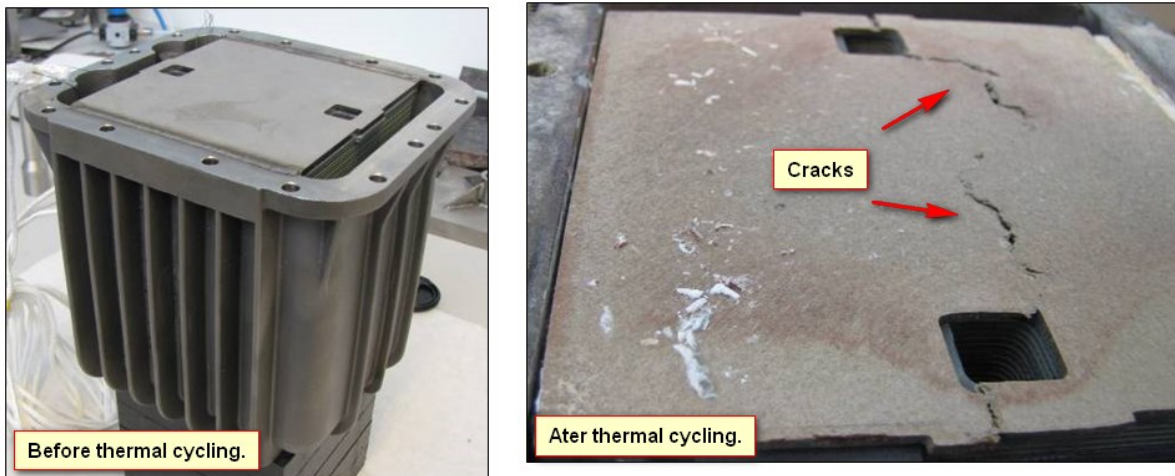

Figure 11: The stack in a module and the gasket between the stack core and the interface plate.

The conclusion was that smooth surfaces should be redesigned to apply raised faces, or simply roughened surfaces, also on interface between the stack module and the boxer manifold. Such changes were implemented in subsequent stacks.

#### 4.6.2 Change of interconnect design

Based on the increased stack demand (2 stacks per system), and in order to improve manufacturability, it was decided to bring in the interconnect used for TOFC's stationary applications. The change took effect in February 2013, and all stacks from "J" and forward are made with this interconnect. The change is sketched in Figure 12.

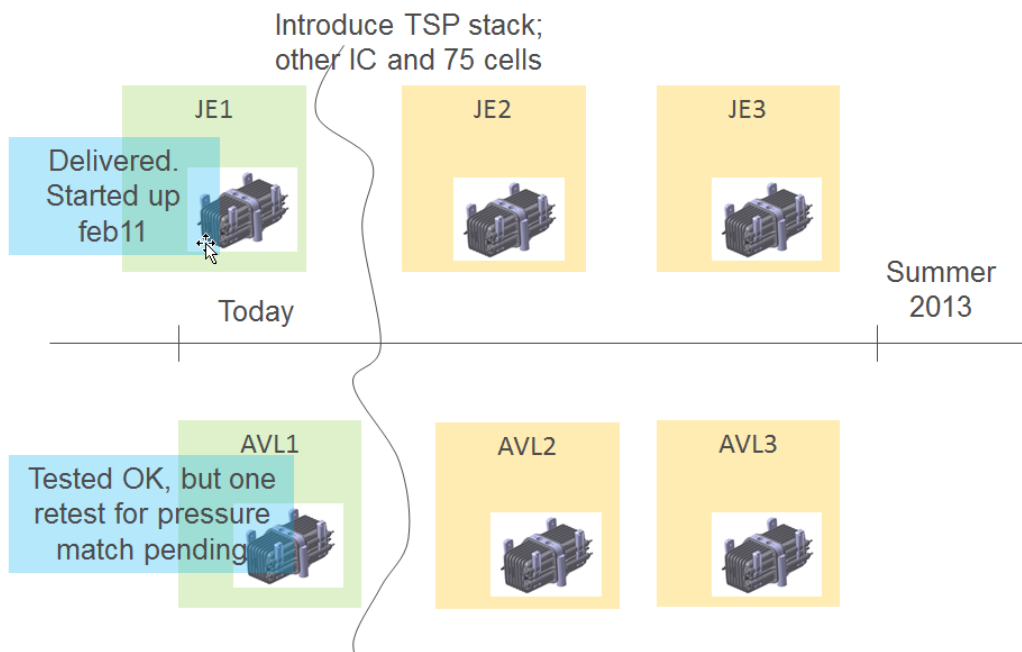

Figure 12: The introduction of the TSP stack geometry in February 2013.

The new design was therefore also used in the last 4 benchmark systems. The TSP interconnect is formed from thin sheet metal, which gives fewer degrees of freedom for the flow geometries. Hence, the stack core has 3 fuel inlets and 3 fuel outlets, which can be seen in Figure 13.

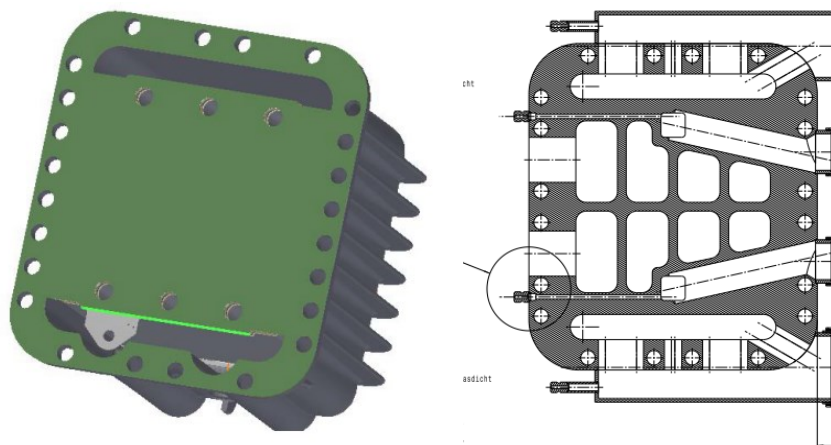

Figure 13: The layout of fuel inlets and outlets in the TSP1 stack. The corresponding boxer manifold design is also shown here.

#### 4.6.3 Final stack design

In the final stack design TOFC estimated that it was critical to get the leakage even further reduced, and hence make the stack even more robust. These changes happened gradually during the fall of 2013 and the spring of 2014.

The leakage solution before these major improvements is shown in Figure 14. This consists of both an inner leakage solution and an outer solution.

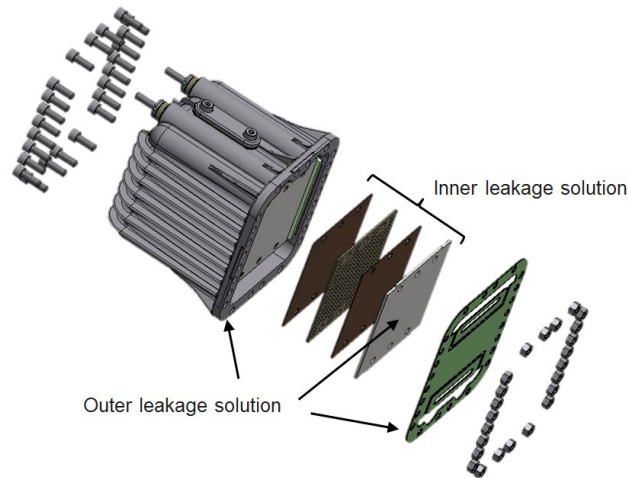

Figure 14: Leakage solution for stack in summer 2013.

The improvements made on the design were to change the design of the welded plate and the gasket layout. On top of that the thickness of the gasket was changed and the design of the surface structure was improved again. Besides these things the steel inlay in the gasket was also changed. These changes resulted in a solution that is shown in Figure 15.

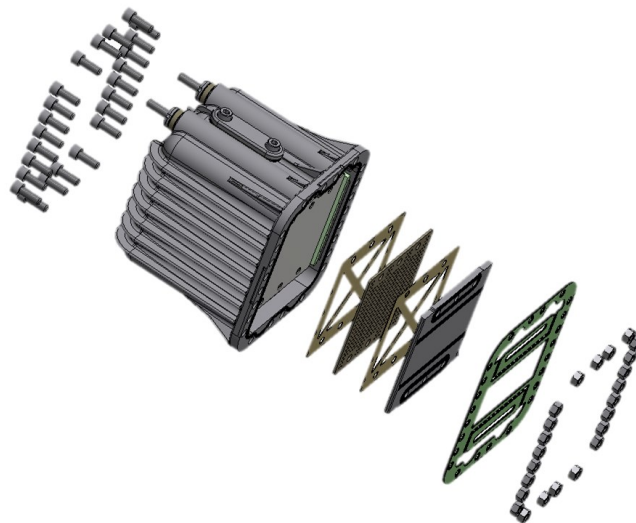

Figure 15: Leakage solution for stack in spring 2014.

The improvements turned out to have successfully reduced both the stack core leakage and also the total leakage when the casing is mounted on a manifold. The actual improvements are shown in numbers in Figure 16, where the anode leakage flows to maintain 100 mbar is shown in different scenarios.

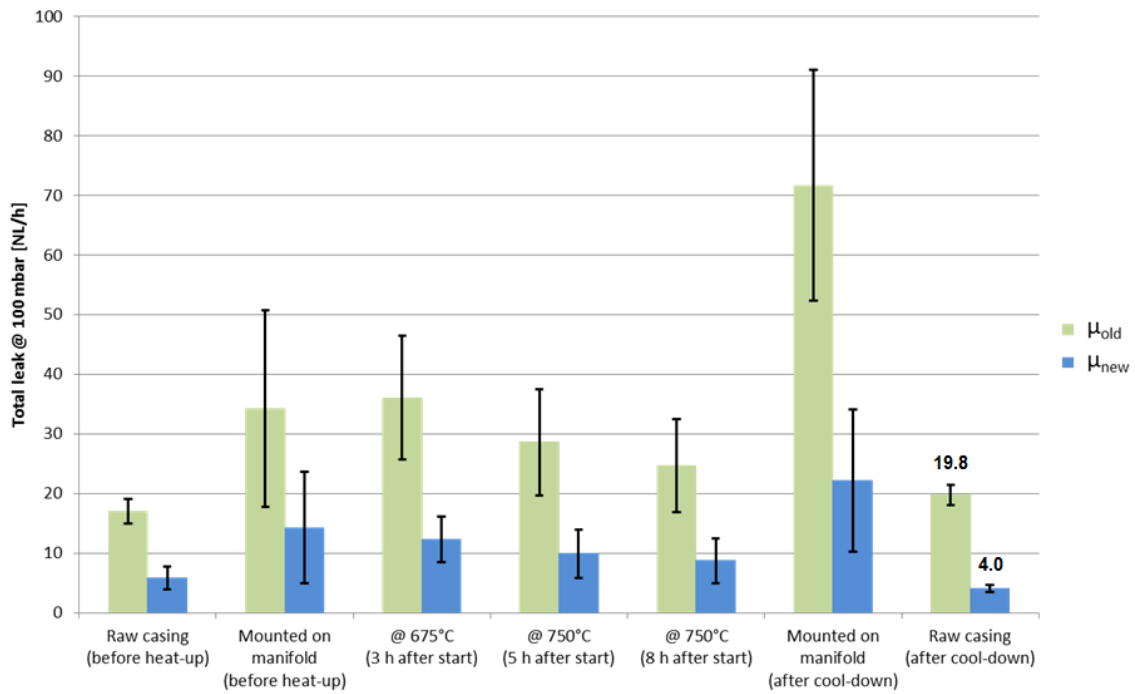

Figure 16: Improvements on leak after change in leakage solution.

These improvements are further elaborated in the deliverable report D3.4

In the following table a complete list of all the stacks delivered from TOFC to the DESTA project is shown.

Stack ID	Partner	Delivery date	Average cell voltage 25 A H <sub>2</sub> (mV)	Remark
R-021	ECCS		895	
R-023	AVL		893	
R-024	ECCS		894	
R-030	ECCS		895	
R-043	ECCS	20-jan	903	
R-046	ECCS	20-jan	902	
Q-333	ECCS	19-mar	897	
Q-334	ECCS	19-mar	897	
Q-345	ECCS	17-maj	885	
Q-347	ECCS	17-maj	885	
R-047	AVL	08-apr	901	
R-052	AVL	08-apr	903	
Q-342	AVL	03-maj	885	
Q-344	AVL	03-maj	885	
Q-350	AVL	14-jun	890	
Q-400	AVL	07-aug	871	
Q-390	ECCS	?	878	"dummy". Not modified
Q-411	ECCS	?	866	"dummy". Not modified
Q-388	ECCS	09-jan	878	
Q-389	ECCS	09-jan	872	
Q-570 + Q-572	ECCS	09-may	893 ; 893	
Q-590 + Q-591	ECCS	23-jul	884 ; 888	
Q-387 + Q-466	ECCS	22-sep	830 ; N/A	Q-466 Accepted on CH <sub>4</sub> operation
Q-624 + Q-612	ECCS	08-oct	904 ; 897	
Q-614 + Q-615	ECCS	08-oct	897; 903	



#### 4.7 Results and achievements

The main result from the period has been the supply of stacks for system development and the improvements on gasket and manifold solutions.

D 3.1: Delivery of modified APU stacks: This was completed on time, but accompanied by an agreement among the partners for the supply of more stacks for the benchmark systems. In total 16 stacks were delivered for one-stack systems and benchmark systems.

D 3.2: Delivery of optimized stacks: This report was slightly delayed, and also this time it was accepted by the consortium that the last stacks could be supplied “on demand”. A total of 12 stacks were delivered to ECCS for integration into the truck demonstrators.

D 3.3: Fuel Tolerance test report: This report was delivered with a minor delay. It did not completely fulfill the original project ambitions.

D 3.4: Lifetime test report: This report was delivered with a minor delay, but documenting how the stacks have been made to fit the requirements of the APU systems.

#### 4.8 Deviations and corrective actions

In this work package there have been 6 deviations.

- (1) Change to two stacks per system: By completion of the requirements report and based on information on the gas composition to be expected, it was evident that the power would not be able to be delivered by just one stack. This has generated some more stack deliveries (updated

plan is to deliver a total of 28 stacks instead of 16 in the DoW). This is addressed in the Annex 1 update, including a budget adjustment agreed among the partners to compensate for this change. This deviation has been handled with only minor impact on fulfillment of the project objectives.

- (2) Focus on seals in robustness activity: The effort of robustness showed that the weakest point of the stack is not the stack core, but rather the gaskets. It turned out that the gasket between the stack modules and the boxer manifold was not sufficiently tight, especially after thermal cycling. A solution was found. The improvements implemented fixed the problem, so this deviation had no impact on fulfillment of the project objectives.
- (3) Obtained thermal cycles. Over the course of the project it was acknowledged in the consortium, that 250 thermal cycles should be sufficient for expected operation. However, the tests did not fully reach this number. 90 cycles was obtained and the stack was still in good shape. So this is considered to have a minor impact on fulfillment of project objectives.
- (4) Anode modifications for Diesel operation: It has been decided not to use Sc-YSZ, but rely on other modifications of the anode. This has had no impact on other WP's.
- (5) M4: Testing 5000 hours on diesel reformat: Due to difficulties establishing a test that would operate with a CPO it was decided to run this test on a simulated gas mixture adding controlled amounts of sulphur. It was done on short stacks with internal manifolding, as the interaction of sulphur and the cell electrochemistry can be evaluated fairly well on such a test platform. The test results showed that without changes to the operating strategy of the stack, the degradation rate is not slow enough to meet the lifetime requirements. Discussions on the implementation of a regeneration concept had started between ECCS and TOFC, but have not concluded by the time of TOFC's exit.
- (6) No tests on diesel additives were performed due to the lack of data on how such additives are have been performed so far. Such additives are heavily transformed in the reformer. As for the testing with diesel additives, a diligent definition of such tests would have requires a detailed analysis of the outlet gas from the reformer in question. This information has not been available for the project.
- (7) The closure of TOFC: This will have only minor impact on the fulfillment of project objectives, but fulfillment of the project purpose is of course affected, since the stacks around which the demonstrator has been designed, will no longer be available.

## 4.9 Conclusions

With regard to the stack supply to the integrators, the work in the work package has progressed satisfactory.

With regard to the stack testing, the test time and number of cycles did not reach all the targets, but on the contrary a larger number of stacks have been tested adding to the confidence that the stacks are fit for the APU application.

With regard to sulphur tolerance, it has not been proven that the stacks can endure the full specified lifetime without losses and a way to implement the regeneration method has not been found.

#### **4.10 Interactions between WP's**

The requirements created in WP1 have been used for defining stack tests and deciding that two stacks were needed.

The collaboration has been rather intense, especially with Eberspächer on the benchmark testing in WP2 and on the testing of the truck demonstrators. This also goes for the packaging studies in which the design was optimized to accommodate the updates on the stack module design. The recording of cell group voltages in the development and benchmark tests at Eberspächer allowed TOFC experts to assist in troubleshooting and adjustment of operating strategies.

Throughout the project TOFC have assisted both integrator partners with know-how and support about the stacks are best operated in the APU systems, and there has been on-site tests of the APU systems at Eberspächer where TOFC stack experts have been present.

#### **Bibliography**

**Im aktuellen Dokument sind keine Quellen vorhanden.**